



Power Sensor Calibration Kits

R&S[®] NRPC18/33/40/50

R&S[®] NRVC

Calibration Software

R&S[®] RECAL +



This manual describes the following power sensor calibration kit types and the calibration software.

Power Sensor Calibration Kits

R&S® NRPC18 order no. 1418.0931.02

R&S® NRPC33 order no. 1418.0677.02

R&S® NRPC40 order no. 1159.6802.02

R&S® NRPC50 order no. 1159.6883.02

R&S® NRVC order no. 1109.0500.02

Calibration Software

R&S® RECAL +

Dear Customer,

R&S® is a registered trademark of Rohde & Schwarz GmbH & Co. KG
Trade names are trademarks of the owners.

Basic Safety Instructions

Always read through and comply with the following safety instructions!

All plants and locations of the Rohde & Schwarz group of companies make every effort to keep the safety standards of our products up to date and to offer our customers the highest possible degree of safety. Our products and the auxiliary equipment they require are designed, built and tested in accordance with the safety standards that apply in each case. Compliance with these standards is continuously monitored by our quality assurance system. The product described here has been designed, built and tested in accordance with the EC Certificate of Conformity and has left the manufacturer's plant in a condition fully complying with safety standards. To maintain this condition and to ensure safe operation, you must observe all instructions and warnings provided in this manual. If you have any questions regarding these safety instructions, the Rohde & Schwarz group of companies will be happy to answer them.

Furthermore, it is your responsibility to use the product in an appropriate manner. This product is designed for use solely in industrial and laboratory environments or, if expressly permitted, also in the field and must not be used in any way that may cause personal injury or property damage. You are responsible if the product is used for any purpose other than its designated purpose or in disregard of the manufacturer's instructions. The manufacturer shall assume no responsibility for such use of the product.

The product is used for its designated purpose if it is used in accordance with its product documentation and within its performance limits (see data sheet, documentation, the following safety instructions). Using the product requires technical skills and, in some cases, a basic knowledge of English. It is therefore essential that only skilled and specialized staff or thoroughly trained personnel with the required skills be allowed to use the product. If personal safety gear is required for using Rohde & Schwarz products, this will be indicated at the appropriate place in the product documentation. Keep the basic safety instructions and the product documentation in a safe place and pass them on to the subsequent users.

Observing the safety instructions will help prevent personal injury or damage of any kind caused by dangerous situations. Therefore, carefully read through and adhere to the following safety instructions before and when using the product. It is also absolutely essential to observe the additional safety instructions on personal safety, for example, that appear in relevant parts of the product documentation. In these safety instructions, the word "product" refers to all merchandise sold and distributed by the Rohde & Schwarz group of companies, including instruments, systems and all accessories. For product-specific information, see the data sheet and the product documentation.

Safety labels on products

The following safety labels are used on products to warn against risks and dangers.

Symbol	Meaning	Symbol	Meaning
	Notice, general danger location Observe product documentation		ON/OFF Power
	Caution when handling heavy equipment		Standby indication
	Danger of electric shock		Direct current (DC)

Basic Safety Instructions

Symbol	Meaning	Symbol	Meaning
	Caution ! Hot surface		Alternating current (AC)
	Protective conductor terminal To identify any terminal which is intended for connection to an external conductor for protection against electric shock in case of a fault, or the terminal of a protective earth		Direct/alternating current (DC/AC)
	Earth (Ground)		Class II Equipment to identify equipment meeting the safety requirements specified for Class II equipment (device protected by double or reinforced insulation)
	Frame or chassis Ground terminal		EU labeling for batteries and accumulators For additional information, see section "Waste disposal/Environmental protection", item 1.
	Be careful when handling electrostatic sensitive devices		EU labeling for separate collection of electrical and electronic devices For additional information, see section "Waste disposal/Environmental protection", item 2.
	Warning! Laser radiation For additional information, see section "Operation", item 7.		

Signal words and their meaning

The following signal words are used in the product documentation in order to warn the reader about risks and dangers.



Indicates a hazardous situation which, if not avoided, will result in death or serious injury.



Indicates a hazardous situation which, if not avoided, could result in death or serious injury.



Indicates a hazardous situation which, if not avoided, could result in minor or moderate injury.



Indicates information considered important, but not hazard-related, e.g. messages relating to property damage.
In the product documentation, the word ATTENTION is used synonymously.

These signal words are in accordance with the standard definition for civil applications in the European Economic Area. Definitions that deviate from the standard definition may also exist in other economic areas or military applications. It is therefore essential to make sure that the signal words described here are always used only in connection with the related product documentation and the related product. The use of signal words in connection with unrelated products or documentation can result in misinterpretation and in personal injury or material damage.

Basic Safety Instructions

Operating states and operating positions

The product may be operated only under the operating conditions and in the positions specified by the manufacturer, without the product's ventilation being obstructed. If the manufacturer's specifications are not observed, this can result in electric shock, fire and/or serious personal injury or death. Applicable local or national safety regulations and rules for the prevention of accidents must be observed in all work performed.

1. Unless otherwise specified, the following requirements apply to Rohde & Schwarz products: predefined operating position is always with the housing floor facing down, IP protection 2X, use only indoors, max. operating altitude 2000 m above sea level, max. transport altitude 4500 m above sea level. A tolerance of $\pm 10\%$ shall apply to the nominal voltage and $\pm 5\%$ to the nominal frequency, overvoltage category 2, pollution degree 2.
2. Do not place the product on surfaces, vehicles, cabinets or tables that for reasons of weight or stability are unsuitable for this purpose. Always follow the manufacturer's installation instructions when installing the product and fastening it to objects or structures (e.g. walls and shelves). An installation that is not carried out as described in the product documentation could result in personal injury or even death.
3. Do not place the product on heat-generating devices such as radiators or fan heaters. The ambient temperature must not exceed the maximum temperature specified in the product documentation or in the data sheet. Product overheating can cause electric shock, fire and/or serious personal injury or even death.

Electrical safety

If the information on electrical safety is not observed either at all or to the extent necessary, electric shock, fire and/or serious personal injury or death may occur.

1. Prior to switching on the product, always ensure that the nominal voltage setting on the product matches the nominal voltage of the mains-supply network. If a different voltage is to be set, the power fuse of the product may have to be changed accordingly.
2. In the case of products of safety class I with movable power cord and connector, operation is permitted only on sockets with a protective conductor contact and protective conductor.
3. Intentionally breaking the protective conductor either in the feed line or in the product itself is not permitted. Doing so can result in the danger of an electric shock from the product. If extension cords or connector strips are implemented, they must be checked on a regular basis to ensure that they are safe to use.
4. If there is no power switch for disconnecting the product from the mains, or if the power switch is not suitable for this purpose, use the plug of the connecting cable to disconnect the product from the mains. In such cases, always ensure that the power plug is easily reachable and accessible at all times. For example, if the power plug is the disconnecting device, the length of the connecting cable must not exceed 3 m. Functional or electronic switches are not suitable for providing disconnection from the AC supply network. If products without power switches are integrated into racks or systems, the disconnecting device must be provided at the system level.
5. Never use the product if the power cable is damaged. Check the power cables on a regular basis to ensure that they are in proper operating condition. By taking appropriate safety measures and carefully laying the power cable, ensure that the cable cannot be damaged and that no one can be hurt by, for example, tripping over the cable or suffering an electric shock.

Basic Safety Instructions

6. The product may be operated only from TN/TT supply networks fuse-protected with max. 16 A (higher fuse only after consulting with the Rohde & Schwarz group of companies).
7. Do not insert the plug into sockets that are dusty or dirty. Insert the plug firmly and all the way into the socket provided for this purpose. Otherwise, sparks that result in fire and/or injuries may occur.
8. Do not overload any sockets, extension cords or connector strips; doing so can cause fire or electric shocks.
9. For measurements in circuits with voltages $V_{rms} > 30$ V, suitable measures (e.g. appropriate measuring equipment, fuse protection, current limiting, electrical separation, insulation) should be taken to avoid any hazards.
10. Ensure that the connections with information technology equipment, e.g. PCs or other industrial computers, comply with the IEC 60950-1 / EN 60950-1 or IEC 61010-1 / EN 61010-1 standards that apply in each case.
11. Unless expressly permitted, never remove the cover or any part of the housing while the product is in operation. Doing so will expose circuits and components and can lead to injuries, fire or damage to the product.
12. If a product is to be permanently installed, the connection between the protective conductor terminal on site and the product's protective conductor must be made first before any other connection is made. The product may be installed and connected only by a licensed electrician.
13. For permanently installed equipment without built-in fuses, circuit breakers or similar protective devices, the supply circuit must be fuse-protected in such a way that anyone who has access to the product, as well as the product itself, is adequately protected from injury or damage.
14. Use suitable overvoltage protection to ensure that no overvoltage (such as that caused by a bolt of lightning) can reach the product. Otherwise, the person operating the product will be exposed to the danger of an electric shock.
15. Any object that is not designed to be placed in the openings of the housing must not be used for this purpose. Doing so can cause short circuits inside the product and/or electric shocks, fire or injuries.
16. Unless specified otherwise, products are not liquid-proof (see also section "Operating states and operating positions", item 1). Therefore, the equipment must be protected against penetration by liquids. If the necessary precautions are not taken, the user may suffer electric shock or the product itself may be damaged, which can also lead to personal injury.
17. Never use the product under conditions in which condensation has formed or can form in or on the product, e.g. if the product has been moved from a cold to a warm environment. Penetration by water increases the risk of electric shock.
18. Prior to cleaning the product, disconnect it completely from the power supply (e.g. AC supply network or battery). Use a soft, non-linting cloth to clean the product. Never use chemical cleaning agents such as alcohol, acetone or diluents for cellulose lacquers.

Operation

1. Operating the products requires special training and intense concentration. Make sure that persons who use the products are physically, mentally and emotionally fit enough to do so; otherwise, injuries or material damage may occur. It is the responsibility of the employer/operator to select suitable personnel for operating the products.

Basic Safety Instructions

2. Before you move or transport the product, read and observe the section titled "Transport".
3. As with all industrially manufactured goods, the use of substances that induce an allergic reaction (allergens) such as nickel cannot be generally excluded. If you develop an allergic reaction (such as a skin rash, frequent sneezing, red eyes or respiratory difficulties) when using a Rohde & Schwarz product, consult a physician immediately to determine the cause and to prevent health problems or stress.
4. Before you start processing the product mechanically and/or thermally, or before you take it apart, be sure to read and pay special attention to the section titled "Waste disposal/Environmental protection", item 1.
5. Depending on the function, certain products such as RF radio equipment can produce an elevated level of electromagnetic radiation. Considering that unborn babies require increased protection, pregnant women must be protected by appropriate measures. Persons with pacemakers may also be exposed to risks from electromagnetic radiation. The employer/operator must evaluate workplaces where there is a special risk of exposure to radiation and, if necessary, take measures to avert the potential danger.
6. Should a fire occur, the product may release hazardous substances (gases, fluids, etc.) that can cause health problems. Therefore, suitable measures must be taken, e.g. protective masks and protective clothing must be worn.
7. Laser products are given warning labels that are standardized according to their laser class. Lasers can cause biological harm due to the properties of their radiation and due to their extremely concentrated electromagnetic power. If a laser product (e.g. a CD/DVD drive) is integrated into a Rohde & Schwarz product, absolutely no other settings or functions may be used as described in the product documentation. The objective is to prevent personal injury (e.g. due to laser beams).
8. EMC classes (in line with EN 55011/CISPR 11, and analogously with EN 55022/CISPR 22, EN 55032/CISPR 32)
 - Class A equipment:
Equipment suitable for use in all environments except residential environments and environments that are directly connected to a low-voltage supply network that supplies residential buildings
Note: Class A equipment is intended for use in an industrial environment. This equipment may cause radio disturbances in residential environments, due to possible conducted as well as radiated disturbances. In this case, the operator may be required to take appropriate measures to eliminate these disturbances.
 - Class B equipment:
Equipment suitable for use in residential environments and environments that are directly connected to a low-voltage supply network that supplies residential buildings

Repair and service

1. The product may be opened only by authorized, specially trained personnel. Before any work is performed on the product or before the product is opened, it must be disconnected from the AC supply network. Otherwise, personnel will be exposed to the risk of an electric shock.

Basic Safety Instructions

- Adjustments, replacement of parts, maintenance and repair may be performed only by electrical experts authorized by Rohde & Schwarz. Only original parts may be used for replacing parts relevant to safety (e.g. power switches, power transformers, fuses). A safety test must always be performed after parts relevant to safety have been replaced (visual inspection, protective conductor test, insulation resistance measurement, leakage current measurement, functional test). This helps ensure the continued safety of the product.

Batteries and rechargeable batteries/cells

If the information regarding batteries and rechargeable batteries/cells is not observed either at all or to the extent necessary, product users may be exposed to the risk of explosions, fire and/or serious personal injury, and, in some cases, death. Batteries and rechargeable batteries with alkaline electrolytes (e.g. lithium cells) must be handled in accordance with the EN 62133 standard.

- Cells must not be taken apart or crushed.
- Cells or batteries must not be exposed to heat or fire. Storage in direct sunlight must be avoided. Keep cells and batteries clean and dry. Clean soiled connectors using a dry, clean cloth.
- Cells or batteries must not be short-circuited. Cells or batteries must not be stored in a box or in a drawer where they can short-circuit each other, or where they can be short-circuited by other conductive materials. Cells and batteries must not be removed from their original packaging until they are ready to be used.
- Cells and batteries must not be exposed to any mechanical shocks that are stronger than permitted.
- If a cell develops a leak, the fluid must not be allowed to come into contact with the skin or eyes. If contact occurs, wash the affected area with plenty of water and seek medical aid.
- Improperly replacing or charging cells or batteries that contain alkaline electrolytes (e.g. lithium cells) can cause explosions. Replace cells or batteries only with the matching Rohde & Schwarz type (see parts list) in order to ensure the safety of the product.
- Cells and batteries must be recycled and kept separate from residual waste. Rechargeable batteries and normal batteries that contain lead, mercury or cadmium are hazardous waste. Observe the national regulations regarding waste disposal and recycling.

Transport

- The product may be very heavy. Therefore, the product must be handled with care. In some cases, the user may require a suitable means of lifting or moving the product (e.g. with a lift-truck) to avoid back or other physical injuries.
- Handles on the products are designed exclusively to enable personnel to transport the product. It is therefore not permissible to use handles to fasten the product to or on transport equipment such as cranes, fork lifts, wagons, etc. The user is responsible for securely fastening the products to or on the means of transport or lifting. Observe the safety regulations of the manufacturer of the means of transport or lifting. Noncompliance can result in personal injury or material damage.
- If you use the product in a vehicle, it is the sole responsibility of the driver to drive the vehicle safely and properly. The manufacturer assumes no responsibility for accidents or collisions. Never use the product in a moving vehicle if doing so could distract the driver of the vehicle. Adequately secure the product in the vehicle to prevent injuries or other damage in the event of an accident.

Instrucciones de seguridad elementales

Waste disposal/Environmental protection

1. Specially marked equipment has a battery or accumulator that must not be disposed of with unsorted municipal waste, but must be collected separately. It may only be disposed of at a suitable collection point or via a Rohde & Schwarz customer service center.
2. Waste electrical and electronic equipment must not be disposed of with unsorted municipal waste, but must be collected separately.
Rohde & Schwarz GmbH & Co. KG has developed a disposal concept and takes full responsibility for take-back obligations and disposal obligations for manufacturers within the EU. Contact your Rohde & Schwarz customer service center for environmentally responsible disposal of the product.
3. If products or their components are mechanically and/or thermally processed in a manner that goes beyond their intended use, hazardous substances (heavy-metal dust such as lead, beryllium, nickel) may be released. For this reason, the product may only be disassembled by specially trained personnel. Improper disassembly may be hazardous to your health. National waste disposal regulations must be observed.
4. If handling the product releases hazardous substances or fuels that must be disposed of in a special way, e.g. coolants or engine oils that must be replenished regularly, the safety instructions of the manufacturer of the hazardous substances or fuels and the applicable regional waste disposal regulations must be observed. Also observe the relevant safety instructions in the product documentation. The improper disposal of hazardous substances or fuels can cause health problems and lead to environmental damage.

For additional information about environmental protection, visit the Rohde & Schwarz website.

Instrucciones de seguridad elementales

¡Es imprescindible leer y cumplir las siguientes instrucciones e informaciones de seguridad!

El principio del grupo de empresas Rohde & Schwarz consiste en tener nuestros productos siempre al día con los estándares de seguridad y de ofrecer a nuestros clientes el máximo grado de seguridad. Nuestros productos y todos los equipos adicionales son siempre fabricados y examinados según las normas de seguridad vigentes. Nuestro sistema de garantía de calidad controla constantemente que sean cumplidas estas normas. El presente producto ha sido fabricado y examinado según el certificado de conformidad de la UE y ha salido de nuestra planta en estado impecable según los estándares técnicos de seguridad. Para poder preservar este estado y garantizar un funcionamiento libre de peligros, el usuario deberá atenerse a todas las indicaciones, informaciones de seguridad y notas de alerta. El grupo de empresas Rohde & Schwarz está siempre a su disposición en caso de que tengan preguntas referentes a estas informaciones de seguridad.

Además queda en la responsabilidad del usuario utilizar el producto en la forma debida. Este producto está destinado exclusivamente al uso en la industria y el laboratorio o, si ha sido expresamente autorizado, para aplicaciones de campo y de ninguna manera deberá ser utilizado de modo que alguna persona/cosa pueda sufrir daño. El uso del producto fuera de sus fines definidos o sin tener en cuenta las instrucciones del fabricante queda en la responsabilidad del usuario. El fabricante no se hace en ninguna forma responsable de consecuencias a causa del mal uso del producto.















Instrucciones de seguridad elementales

Se parte del uso correcto del producto para los fines definidos si el producto es utilizado conforme a las indicaciones de la correspondiente documentación del producto y dentro del margen de rendimiento definido (ver hoja de datos, documentación, informaciones de seguridad que siguen). El uso del producto hace necesarios conocimientos técnicos y ciertos conocimientos del idioma inglés. Por eso se debe tener en cuenta que el producto solo pueda ser operado por personal especializado o personas instruidas en profundidad con las capacidades correspondientes. Si fuera necesaria indumentaria de seguridad para el uso de productos de Rohde & Schwarz, encontraría la información debida en la documentación del producto en el capítulo correspondiente. Guarde bien las informaciones de seguridad elementales, así como la documentación del producto, y entréguelas a usuarios posteriores.

Tener en cuenta las informaciones de seguridad sirve para evitar en lo posible lesiones o daños por peligros de toda clase. Por eso es imprescindible leer detalladamente y comprender por completo las siguientes informaciones de seguridad antes de usar el producto, y respetarlas durante el uso del producto. Deberán tenerse en cuenta todas las demás informaciones de seguridad, como p. ej. las referentes a la protección de personas, que encontrarán en el capítulo correspondiente de la documentación del producto y que también son de obligado cumplimiento. En las presentes informaciones de seguridad se recogen todos los objetos que distribuye el grupo de empresas Rohde & Schwarz bajo la denominación de "producto", entre ellos también aparatos, instalaciones así como toda clase de accesorios. Los datos específicos del producto figuran en la hoja de datos y en la documentación del producto.

Señalización de seguridad de los productos

Las siguientes señales de seguridad se utilizan en los productos para advertir sobre riesgos y peligros.

Símbolo	Significado	Símbolo	Significado
	Aviso: punto de peligro general Observar la documentación del producto		Tensión de alimentación de PUESTA EN MARCHA / PARADA
	Atención en el manejo de dispositivos de peso elevado		Indicación de estado de espera (standby)
	Peligro de choque eléctrico		Corriente continua (DC)
	Advertencia: superficie caliente		Corriente alterna (AC)
	Conexión a conductor de protección		Corriente continua / Corriente alterna (DC/AC)
	Conexión a tierra		El aparato está protegido en su totalidad por un aislamiento doble (reforzado)
	Conexión a masa		Distintivo de la UE para baterías y acumuladores Más información en la sección "Eliminación/protección del medio ambiente", punto 1.

Instrucciones de seguridad elementales

Símbolo	Significado	Símbolo	Significado
	Aviso: Cuidado en el manejo de dispositivos sensibles a la electrostática (ESD)		Distintivo de la UE para la eliminación por separado de dispositivos eléctricos y electrónicos Más información en la sección "Eliminación/protección del medio ambiente", punto 2.
	Advertencia: rayo láser Más información en la sección "Funcionamiento", punto 7.		

Palabras de señal y su significado

En la documentación del producto se utilizan las siguientes palabras de señal con el fin de advertir contra riesgos y peligros.



Indica una situación de peligro que, si no se evita, causa lesiones graves o incluso la muerte.



Indica una situación de peligro que, si no se evita, puede causar lesiones graves o incluso la muerte.



Indica una situación de peligro que, si no se evita, puede causar lesiones leves o moderadas.



Indica información que se considera importante, pero no en relación con situaciones de peligro; p. ej., avisos sobre posibles daños materiales.

En la documentación del producto se emplea de forma sinónima el término CUIDADO.

Las palabras de señal corresponden a la definición habitual para aplicaciones civiles en el área económica europea. Pueden existir definiciones diferentes a esta definición en otras áreas económicas o en aplicaciones militares. Por eso se deberá tener en cuenta que las palabras de señal aquí descritas sean utilizadas siempre solamente en combinación con la correspondiente documentación del producto y solamente en combinación con el producto correspondiente. La utilización de las palabras de señal en combinación con productos o documentaciones que no les correspondan puede llevar a interpretaciones equivocadas y tener por consecuencia daños en personas u objetos.

Estados operativos y posiciones de funcionamiento

El producto solamente debe ser utilizado según lo indicado por el fabricante respecto a los estados operativos y posiciones de funcionamiento sin que se obstruya la ventilación. Si no se siguen las indicaciones del fabricante, pueden producirse choques eléctricos, incendios y/o lesiones graves con posible consecuencia de muerte. En todos los trabajos deberán ser tenidas en cuenta las normas nacionales y locales de seguridad del trabajo y de prevención de accidentes.

Instrucciones de seguridad elementales

1. Si no se convino de otra manera, es para los productos Rohde & Schwarz válido lo que sigue: como posición de funcionamiento se define por principio la posición con el suelo de la caja para abajo, modo de protección IP 2X, uso solamente en estancias interiores, utilización hasta 2000 m sobre el nivel del mar, transporte hasta 4500 m sobre el nivel del mar. Se aplicará una tolerancia de $\pm 10\%$ sobre el voltaje nominal y de $\pm 5\%$ sobre la frecuencia nominal. Categoría de sobrecarga eléctrica 2, índice de suciedad 2.
2. No sitúe el producto encima de superficies, vehículos, estantes o mesas, que por sus características de peso o de estabilidad no sean aptos para él. Siga siempre las instrucciones de instalación del fabricante cuando instale y asegure el producto en objetos o estructuras (p. ej. paredes y estantes). Si se realiza la instalación de modo distinto al indicado en la documentación del producto, se pueden causar lesiones o, en determinadas circunstancias, incluso la muerte.
3. No ponga el producto sobre aparatos que generen calor (p. ej. radiadores o calefactores). La temperatura ambiente no debe superar la temperatura máxima especificada en la documentación del producto o en la hoja de datos. En caso de sobrecalentamiento del producto, pueden producirse choques eléctricos, incendios y/o lesiones graves con posible consecuencia de muerte.

Seguridad eléctrica

Si no se siguen (o se siguen de modo insuficiente) las indicaciones del fabricante en cuanto a seguridad eléctrica, pueden producirse choques eléctricos, incendios y/o lesiones graves con posible consecuencia de muerte.

1. Antes de la puesta en marcha del producto se deberá comprobar siempre que la tensión preseleccionada en el producto coincida con la de la red de alimentación eléctrica. Si es necesario modificar el ajuste de tensión, también se deberán cambiar en caso dado los fusibles correspondientes del producto.
2. Los productos de la clase de protección I con alimentación móvil y enchufe individual solamente podrán enchufarse a tomas de corriente con contacto de seguridad y con conductor de protección conectado.
3. Queda prohibida la interrupción intencionada del conductor de protección, tanto en la toma de corriente como en el mismo producto. La interrupción puede tener como consecuencia el riesgo de que el producto sea fuente de choques eléctricos. Si se utilizan cables alargadores o regletas de enchufe, deberá garantizarse la realización de un examen regular de los mismos en cuanto a su estado técnico de seguridad.
4. Si el producto no está equipado con un interruptor para desconectarlo de la red, o bien si el interruptor existente no resulta apropiado para la desconexión de la red, el enchufe del cable de conexión se deberá considerar como un dispositivo de desconexión. El dispositivo de desconexión se debe poder alcanzar fácilmente y debe estar siempre bien accesible. Si, p. ej., el enchufe de conexión a la red es el dispositivo de desconexión, la longitud del cable de conexión no debe superar 3 m). Los interruptores selectores o electrónicos no son aptos para el corte de la red eléctrica. Si se integran productos sin interruptor en bastidores o instalaciones, se deberá colocar el interruptor en el nivel de la instalación.
5. No utilice nunca el producto si está dañado el cable de conexión a red. Compruebe regularmente el correcto estado de los cables de conexión a red. Asegúrese, mediante las medidas de protección y de instalación adecuadas, de que el cable de conexión a red no pueda ser dañado o de que nadie pueda ser dañado por él, p. ej. al tropezar o por un choque eléctrico.

Instrucciones de seguridad elementales

6. Solamente está permitido el funcionamiento en redes de alimentación TN/TT aseguradas con fusibles de 16 A como máximo (utilización de fusibles de mayor amperaje solo previa consulta con el grupo de empresas Rohde & Schwarz).
7. Nunca conecte el enchufe en tomas de corriente sucias o llenas de polvo. Introduzca el enchufe por completo y fuertemente en la toma de corriente. La no observación de estas medidas puede provocar chispas, fuego y/o lesiones.
8. No sobrecargue las tomas de corriente, los cables alargadores o las regletas de enchufe ya que esto podría causar fuego o choques eléctricos.
9. En las mediciones en circuitos de corriente con una tensión $U_{\text{eff}} > 30 \text{ V}$ se deberán tomar las medidas apropiadas para impedir cualquier peligro (p. ej. medios de medición adecuados, seguros, limitación de tensión, corte protector, aislamiento etc.).
10. Para la conexión con dispositivos informáticos como un PC o un ordenador industrial, debe comprobarse que éstos cumplan los estándares IEC60950-1/EN60950-1 o IEC61010-1/EN 61010-1 válidos en cada caso.
11. A menos que esté permitido expresamente, no retire nunca la tapa ni componentes de la carcasa mientras el producto esté en servicio. Esto pone a descubierto los cables y componentes eléctricos y puede causar lesiones, fuego o daños en el producto.
12. Si un producto se instala en un lugar fijo, se deberá primero conectar el conductor de protección fijo con el conductor de protección del producto antes de hacer cualquier otra conexión. La instalación y la conexión deberán ser efectuadas por un electricista especializado.
13. En el caso de dispositivos fijos que no estén provistos de fusibles, interruptor automático ni otros mecanismos de seguridad similares, el circuito de alimentación debe estar protegido de modo que todas las personas que puedan acceder al producto, así como el producto mismo, estén a salvo de posibles daños.
14. Todo producto debe estar protegido contra sobretensión (debida p. ej. a una caída del rayo) mediante los correspondientes sistemas de protección. Si no, el personal que lo utilice quedará expuesto al peligro de choque eléctrico.
15. No debe introducirse en los orificios de la caja del aparato ningún objeto que no esté destinado a ello. Esto puede producir cortocircuitos en el producto y/o puede causar choques eléctricos, fuego o lesiones.
16. Salvo indicación contraria, los productos no están impermeabilizados (ver también el capítulo "Estados operativos y posiciones de funcionamiento", punto 1). Por eso es necesario tomar las medidas necesarias para evitar la entrada de líquidos. En caso contrario, existe peligro de choque eléctrico para el usuario o de daños en el producto, que también pueden redundar en peligro para las personas.
17. No utilice el producto en condiciones en las que pueda producirse o ya se hayan producido condensaciones sobre el producto o en el interior de éste, como p. ej. al desplazarlo de un lugar frío a otro caliente. La entrada de agua aumenta el riesgo de choque eléctrico.
18. Antes de la limpieza, desconecte por completo el producto de la alimentación de tensión (p. ej. red de alimentación o batería). Realice la limpieza de los aparatos con un paño suave, que no se deshilache. No utilice bajo ningún concepto productos de limpieza químicos como alcohol, acetona o diluyentes para lacas nitrocelulósicas.

Instrucciones de seguridad elementales

Funcionamiento

1. El uso del producto requiere instrucciones especiales y una alta concentración durante el manejo. Debe asegurarse que las personas que manejen el producto estén a la altura de los requerimientos necesarios en cuanto a aptitudes físicas, psíquicas y emocionales, ya que de otra manera no se pueden excluir lesiones o daños de objetos. El empresario u operador es responsable de seleccionar el personal usuario apto para el manejo del producto.
2. Antes de desplazar o transportar el producto, lea y tenga en cuenta el capítulo "Transporte".
3. Como con todo producto de fabricación industrial no puede quedar excluida en general la posibilidad de que se produzcan alergias provocadas por algunos materiales empleados —los llamados alérgenos (p. ej. el níquel)—. Si durante el manejo de productos Rohde & Schwarz se producen reacciones alérgicas, como p. ej. irritaciones cutáneas, estornudos continuos, enrojecimiento de la conjuntiva o dificultades respiratorias, debe avisarse inmediatamente a un médico para investigar las causas y evitar cualquier molestia o daño a la salud.
4. Antes de la manipulación mecánica y/o térmica o el desmontaje del producto, debe tenerse en cuenta imprescindiblemente el capítulo "Eliminación/protección del medio ambiente", punto 1.
5. Ciertos productos, como p. ej. las instalaciones de radiocomunicación RF, pueden a causa de su función natural, emitir una radiación electromagnética aumentada. Deben tomarse todas las medidas necesarias para la protección de las mujeres embarazadas. También las personas con marcapasos pueden correr peligro a causa de la radiación electromagnética. El empresario/operador tiene la obligación de evaluar y señalar las áreas de trabajo en las que exista un riesgo elevado de exposición a radiaciones.
6. Tenga en cuenta que en caso de incendio pueden desprenderse del producto sustancias tóxicas (gases, líquidos etc.) que pueden generar daños a la salud. Por eso, en caso de incendio deben usarse medidas adecuadas, como p. ej. máscaras antigás e indumentaria de protección.
7. Los productos con láser están provistos de indicaciones de advertencia normalizadas en función de la clase de láser del que se trate. Los rayos láser pueden provocar daños de tipo biológico a causa de las propiedades de su radiación y debido a su concentración extrema de potencia electromagnética. En caso de que un producto Rohde & Schwarz contenga un producto láser (p. ej. un lector de CD/DVD), no debe usarse ninguna otra configuración o función aparte de las descritas en la documentación del producto, a fin de evitar lesiones (p. ej. debidas a irradiación láser).
8. Clases de compatibilidad electromagnética (conforme a EN 55011 / CISPR 11; y en analogía con EN 55022 / CISPR 22, EN 55032 / CISPR 32)
 - Aparato de clase A:
Aparato adecuado para su uso en todos los entornos excepto en los residenciales y en aquellos conectados directamente a una red de distribución de baja tensión que suministra corriente a edificios residenciales.
Nota: Los aparatos de clase A están destinados al uso en entornos industriales. Estos aparatos pueden causar perturbaciones radioeléctricas en entornos residenciales debido a posibles perturbaciones guiadas o radiadas. En este caso, se le podrá solicitar al operador que tome las medidas adecuadas para eliminar estas perturbaciones.
 - Aparato de clase B:
Aparato adecuado para su uso en entornos residenciales, así como en aquellos conectados directamente a una red de distribución de baja tensión que suministra corriente a edificios residenciales.

Instrucciones de seguridad elementales

Reparación y mantenimiento

1. El producto solamente debe ser abierto por personal especializado con autorización para ello. Antes de manipular el producto o abrirlo, es obligatorio desconectarlo de la tensión de alimentación, para evitar toda posibilidad de choque eléctrico.
2. El ajuste, el cambio de partes, el mantenimiento y la reparación deberán ser efectuadas solamente por electricistas autorizados por Rohde & Schwarz. Si se reponen partes con importancia para los aspectos de seguridad (p. ej. el enchufe, los transformadores o los fusibles), solamente podrán ser sustituidos por partes originales. Después de cada cambio de partes relevantes para la seguridad deberá realizarse un control de seguridad (control a primera vista, control del conductor de protección, medición de resistencia de aislamiento, medición de la corriente de fuga, control de funcionamiento). Con esto queda garantizada la seguridad del producto.

Baterías y acumuladores o celdas

Si no se siguen (o se siguen de modo insuficiente) las indicaciones en cuanto a las baterías y acumuladores o celdas, pueden producirse explosiones, incendios y/o lesiones graves con posible consecuencia de muerte. El manejo de baterías y acumuladores con electrolitos alcalinos (p. ej. celdas de litio) debe seguir el estándar EN 62133.

1. No deben desmontarse, abrirse ni triturarse las celdas.
2. Las celdas o baterías no deben someterse a calor ni fuego. Debe evitarse el almacenamiento a la luz directa del sol. Las celdas y baterías deben mantenerse limpias y secas. Limpiar las conexiones sucias con un paño seco y limpio.
3. Las celdas o baterías no deben cortocircuitarse. Es peligroso almacenar las celdas o baterías en estuches o cajones en cuyo interior puedan cortocircuitarse por contacto recíproco o por contacto con otros materiales conductores. No deben extraerse las celdas o baterías de sus embalajes originales hasta el momento en que vayan a utilizarse.
4. Las celdas o baterías no deben someterse a impactos mecánicos fuertes indebidos.
5. En caso de falta de estanqueidad de una celda, el líquido vertido no debe entrar en contacto con la piel ni los ojos. Si se produce contacto, lavar con agua abundante la zona afectada y avisar a un médico.
6. En caso de cambio o recarga inadecuados, las celdas o baterías que contienen electrolitos alcalinos (p. ej. las celdas de litio) pueden explotar. Para garantizar la seguridad del producto, las celdas o baterías solo deben ser sustituidas por el tipo Rohde & Schwarz correspondiente (ver lista de recambios).
7. Las baterías y celdas deben reciclarse y no deben tirarse a la basura doméstica. Las baterías o acumuladores que contienen plomo, mercurio o cadmio deben tratarse como residuos especiales. Respete en esta relación las normas nacionales de eliminación y reciclaje.

Transporte

1. El producto puede tener un peso elevado. Por eso es necesario desplazarlo o transportarlo con precaución y, si es necesario, usando un sistema de elevación adecuado (p. ej. una carretilla elevadora), a fin de evitar lesiones en la espalda u otros daños personales.

Instrucciones de seguridad elementales

2. Las asas instaladas en los productos sirven solamente de ayuda para el transporte del producto por personas. Por eso no está permitido utilizar las asas para la sujeción en o sobre medios de transporte como p. ej. grúas, carretillas elevadoras de horquilla, carros etc. Es responsabilidad suya fijar los productos de manera segura a los medios de transporte o elevación. Para evitar daños personales o daños en el producto, siga las instrucciones de seguridad del fabricante del medio de transporte o elevación utilizado.
3. Si se utiliza el producto dentro de un vehículo, recae de manera exclusiva en el conductor la responsabilidad de conducir el vehículo de manera segura y adecuada. El fabricante no asumirá ninguna responsabilidad por accidentes o colisiones. No utilice nunca el producto dentro de un vehículo en movimiento si esto pudiera distraer al conductor. Asegure el producto dentro del vehículo debidamente para evitar, en caso de un accidente, lesiones u otra clase de daños.

Eliminación/protección del medio ambiente

1. Los dispositivos marcados contienen una batería o un acumulador que no se debe desechar con los residuos domésticos sin clasificar, sino que debe ser recogido por separado. La eliminación se debe efectuar exclusivamente a través de un punto de recogida apropiado o del servicio de atención al cliente de Rohde & Schwarz.
2. Los dispositivos eléctricos usados no se deben desechar con los residuos domésticos sin clasificar, sino que deben ser recogidos por separado.
Rohde & Schwarz GmbH & Co.KG ha elaborado un concepto de eliminación de residuos y asume plenamente los deberes de recogida y eliminación para los fabricantes dentro de la UE. Para desechar el producto de manera respetuosa con el medio ambiente, dirijase a su servicio de atención al cliente de Rohde & Schwarz.
3. Si se trabaja de manera mecánica y/o térmica cualquier producto o componente más allá del funcionamiento previsto, pueden liberarse sustancias peligrosas (polvos con contenido de metales pesados como p. ej. plomo, berilio o níquel). Por eso el producto solo debe ser desmontado por personal especializado con formación adecuada. Un desmontaje inadecuado puede ocasionar daños para la salud. Se deben tener en cuenta las directivas nacionales referentes a la eliminación de residuos.
4. En caso de que durante el trato del producto se formen sustancias peligrosas o combustibles que deban tratarse como residuos especiales (p. ej. refrigerantes o aceites de motor con intervalos de cambio definidos), deben tenerse en cuenta las indicaciones de seguridad del fabricante de dichas sustancias y las normas regionales de eliminación de residuos. Tenga en cuenta también en caso necesario las indicaciones de seguridad especiales contenidas en la documentación del producto. La eliminación incorrecta de sustancias peligrosas o combustibles puede causar daños a la salud o daños al medio ambiente.

Se puede encontrar más información sobre la protección del medio ambiente en la página web de Rohde & Schwarz.

Quality management and environmental management

Certified Quality System
ISO 9001

Certified Environmental System
ISO 14001

Sehr geehrter Kunde,

Sie haben sich für den Kauf eines Rohde&Schwarz Produktes entschieden. Sie erhalten damit ein nach modernsten Fertigungsmethoden hergestelltes Produkt. Es wurde nach den Regeln unserer Qualitäts- und Umweltmanagementsysteme entwickelt, gefertigt und geprüft. Rohde&Schwarz ist unter anderem nach den Managementsystemen ISO9001 und ISO 14001 zertifiziert.

Der Umwelt verpflichtet

- Energie-effiziente, RoHS-konforme Produkte
- Kontinuierliche Weiterentwicklung nachhaltiger Umweltkonzepte
- ISO 14001-zertifiziertes Umweltmanagementsystem

Dear customer,

You have decided to buy a Rohde&Schwarz product. This product has been manufactured using the most advanced methods. It was developed, manufactured and tested in compliance with our quality management and environmental management systems. Rohde&Schwarz has been certified, for example, according to the ISO9001 and ISO 14001 management systems.

Environmental commitment

- Energy-efficient products
- Continuous improvement in environmental sustainability
- ISO 14001-certified environmental management system

Cher client,

Vous avez choisi d'acheter un produit Rohde&Schwarz. Vous disposez donc d'un produit fabriqué d'après les méthodes les plus avancées. Le développement, la fabrication et les tests de ce produit ont été effectués selon nos systèmes de management de qualité et de management environnemental. La société Rohde&Schwarz a été homologuée, entre autres, conformément aux systèmes de management ISO 9001 et ISO 14001.

Engagement écologique

- Produits à efficience énergétique
- Amélioration continue de la durabilité environnementale
- Système de management environnemental certifié selon ISO 14001



Customer Support

Technical support – where and when you need it

For quick, expert help with any Rohde & Schwarz equipment, contact one of our Customer Support Centers. A team of highly qualified engineers provides telephone support and will work with you to find a solution to your query on any aspect of the operation, programming or applications of Rohde & Schwarz equipment.

Up-to-date information and upgrades

To keep your instrument up-to-date and to be informed about new application notes related to your instrument, please send an e-mail to the Customer Support Center stating your instrument and your wish. We will take care that you will get the right information.

Europe, Africa, Middle East

Phone +49 89 4129 12345
customersupport@rohde-schwarz.com

North America

Phone 1-888-TEST-RSA (1-888-837-8772)
customer.support@rsa.rohde-schwarz.com

Latin America

Phone +1-410-910-7988
customersupport.la@rohde-schwarz.com

Asia/Pacific

Phone +65 65 13 04 88
customersupport.asia@rohde-schwarz.com

China

Phone +86-800-810-8228 /
+86-400-650-5896
customersupport.china@rohde-schwarz.com



Contents

1 General 6

Description of the Calibration Kits 6

 Information about the R&S®NRPC Calibration Kit 7

 Information about the R&S®NRVC Calibration Kit 7

Information and Instructions on Calibration 8

 Warm-Up Time for Devices under Test (DUTs) 8

 Reflection Measurement 8

 Calibration of Absolute Accuracy 8

 Refreshing the Device under Test's Data Set 8

 Gamma Correction 9

 R&S®NRP-Z Sensors with Attenuator 9

 Diode Sensors in the R&S®NRV and R&S®URV5 Families 9

 Linearity Calibration 9

 Information about the Supported Sensors 10

2 Putting into Operation 12

Unpacking the Unit 12

 R&S®NRPC18 and R&S®NRPC18-B1 12

 R&S®NRPC33 and R&S®NRPC33-B1 13

 R&S®NRPC40 and R&S®NRPC40-B1 14

 R&S®NRPC50 and R&S®NRPC50-B1 15

 R&S®NRVC-B2 16

Additional Hardware Requirements 17

 Devices for the R&S®NRPC and R&S®NRVC Calibration Kit 17

 Controller 17

 R&S®NRP-ZK6 interface cable 17

 Generators for Calibration of Absolute Accuracy 18

 Vector Network Analyzers for Calibration of Matching 20

 Devices for the R&S®NRPC Calibration Kit 22

 R&S®NRP2 Base Unit 22

 R&S®NRVD Dual-Channel Power Meter 22

 Devices for the R&S®NRVC Calibration Kit 23

 R&S®NRVD Dual-Channel Power Meter 23

 R&S®NRP2 Base Unit 23

 Operation of the R&S®NRVC-B2 Calibration Kit 23

 Generator for Calibration of Linearity 23

Power Calibration with the R&S®NRPC18 Calibration Kit	24
R&S®NRP Sensors up to 18 GHz	24
R&S®FSH-Z1, -Z18	24
R&S®NRV-Z2, -Z5, -Z8, -Z51	25
R&S®NRV-Z32	25
R&S®NRV-Z33, -Z53, -Z54.....	26
R&S®NRV-Z1, -Z4, -Z7, -Z31	26
R&S®URV5-Z2	27
R&S®URV5-Z4	27
R&S®URV5-Z7	28
Power Calibration with the R&S®NRPC33 Calibration Kit	29
R&S®NRP Sensors up to 33 GHz	29
R&S®NRV-Z52	29
R&S®NRV-Z6	30
Power Calibration with the R&S®NRPC40 Calibration Kit	31
R&S®NRP Sensors up to 40 GHz	31
R&S®NRV-Z55	31
R&S®NRV-Z15	32
Power Calibration with the R&S®NRPC50 Calibration Kit	33
R&S®NRP Sensors up to 50 GHz	33
Linearity Calibration with the R&S®NRVC-B2 Option	34
R&S®NRP Sensors.....	34
R&S®FSH-Z1, -Z18	35
R&S®NRV-Z1, -Z4, -Z7, -Z31, -Z51, -Z52, -Z55.....	35
R&S®NRV-Z32, -Z33, -Z53, -Z54	36
R&S®NRV-Z2, -Z5, -Z8.....	36
R&S®URV5-Z7	37
R&S®URV5-Z2, -Z4	37
3 Sensor Calibration	38
Preparation	38
Installing the R&S®Recal+ Calibration Software on the Hard Disk.....	38
Installing the R&S®ZVX_RECAL Additional Program on the Hard Disk.....	38
Starting the Calibration Software	39
Entering the Name and Address of the Calibration Laboratory.....	40
Defining Directories	40
Update Additional Data for the R&S®NRVC Calibration Kit.....	41
Initializing the Measuring Equipment.....	42
Configuration of Power Meters with the R&S®NRPC Calibration Kit.....	42
Configuration of Power Meters with the R&S®NRVC Calibration Kit.....	44
Performing the Calibration.....	50
Incoming Inspection	52
Checking the Matching	53
Checking the Linearity.....	53
Checking the Absolute Accuracy.....	56

Generating the Calibration Report	60
Suppressing the Rohde & Schwarz logo	61
Calculating a New EPROM File	62
Overwriting the Data Memory of a Sensor with Flash EPROM	63
Archiving	64
Copying Files to Archive	65
Fetching Files from Archive.....	65
4 Verification	66
Verification of the R&S®NRPC Calibration Kit	66
Built-In Self-Test of the Power Standard	66
Comparison Measurements with the R&S®NRPC-B1 Verification Set.....	66
Verification of the R&S®NRVC Calibration Kit.....	68
Comparison Measurements with the R&S®NRVC-B1 Verification Set.....	68
DC Voltage Tests with the R&S®NRVC Calibration Kit	69
Additional measuring equipment required.....	71
Measurement procedure	72
5 Recalibration	74
Procedures to be Performed after Recalibration	74
6 Appendix	75
Exchanging the RF Connector on the Test Port of the Power Standard	75
Measurements on a Separate Measurement Setup	77
Reflection.....	77
Program-Controlled Reflection Measurement with <i>R&S®ZVX_RECAL</i>	77
Information about reflection measurements with <i>R&S®ZVX_RECAL</i>	83
Reflection measurement without using <i>R&S®ZVX_RECAL</i>	85
Configuration of the Network Analyzer	85
Formatting and Saving the Reflection Measured Values	86
S-parameter file for sensors with attenuators.....	92
Linearity	94
Absolute Accuracy.....	97
Measurement Uncertainty	100
Calibration of Absolute Accuracy.....	100
Linearity	115

1 General

Various calibration kits are available for calibration of sensors depending on the frequency range. Calibration of the sensors is supported by the **R&S®Recal+** software. All of the calibration kits are calibrated in a traceable manner by Deutscher Kalibrierdienst laboratory D-K-15195-01-00. This laboratory is accredited by the Deutsche Akkreditierungsstelle GmbH for the relevant measured quantities (reflection, equivalent reflection and RF power). The appendix to the accreditation certificate can be found on the Internet at www.dakks.de.

The calibration kits support the following functions:

- Calibration of absolute accuracy for power sensors with N-50Ω, 3.5 mm, 2.92 mm and 2.4 mm connectors from DC to max. 50 GHz
- Linearity calibration with a level range of -30 dBm to +33 dBm at 50 MHz
- Recording of the reflection with the additional program **R&S®ZVX_RECAL**
- Computation of new correction factors for the data memories based on the calibration data *)
- Rewriting to the data memories
- Report generation

*) For certain sensors (see Table 1-4 to Table 1-7), calibration is performed without rewriting the data memory.

Note: This document refers to the R&S®NRPC33, R&S®NRPC40 and R&S®NRPC50 calibration kits using the general designation R&S®NRPC.

Description of the Calibration Kits

The R&S®NRPC calibration kits support the common connector types that are used in the frequency range up to 50 GHz (Table 1-1). For the N-50Ω connector type, the predecessor model R&S®NRVC is also listed which is still supported by the current **R&S®Recal+** calibration software.

Table 1-1 Calibration kits

Calibration kit	Connector type	Meas. level	Frequency range
R&S®NRVC	N-50Ω	-30 dBm (1 μW) to +20 dBm (20 mW)	DC to 18 GHz
R&S®NRPC18	N-50Ω	-40 dBm (0.1 μW) to +20 dBm (20 mW)	DC to 18 GHz
R&S®NRPC33	3.5 mm	-40 dBm (0.1 μW) to +20 dBm (20 mW)	DC to 33 GHz
R&S®NRPC40	2.92 mm	-40 dBm (0.1 μW) to +20 dBm (20 mW)	DC to 40 GHz
R&S®NRPC50	2.4 mm	-20 dBm (10 μW) to +20 dBm (20 mW)	DC to 50 GHz

Table 1-2 Options for the R&S®NRVC calibration kit

Option	Connector type	Function	Frequency range
R&S®NRVC-B1	N-50Ω	For verification R&S®NRVC	10 MHz to 18 GHz
R&S®NRVC-B2	N-50Ω	For linearity calibration of sensors	50 MHz

The option R&S®NRVC-B1 is a verification set for the power standard in the R&S®NRVC calibration kit. Each verification set contains two appropriate sensors for the given power standard.

The option R&S[®]NRVC-B2 is a linearity standard that makes it possible to verify the linearity of power sensors at 50 MHz. This function is also possible in conjunction with the R&S[®]NRPC calibration kits, but an R&S[®]NRVD base unit and a suitable generator are required.

Table 1-3 Options for the R&S[®]NRPC calibration kits

Option	Connector type	Function	Frequency range
R&S [®] NRPC18-B1	N-50Ω	For verification R&S [®] NRPC18	10 MHz to 18 GHz
R&S [®] NRPC33-B1	3.5 mm	For verification R&S [®] NRPC33	10 MHz to 33 GHz
R&S [®] NRPC40-B1	2.92 mm	For verification R&S [®] NRPC40	10 MHz to 40 GHz
R&S [®] NRPC50-B1	2.4 mm	For verification R&S [®] NRPC50	10 MHz to 50 GHz

The R&S[®]NRPC-B1 options are verification sets for the power standards in the R&S[®]NRPC calibration kits. Each verification set contains a thermal sensor that is appropriate for the power standard.

Information about the R&S[®]NRPC Calibration Kit

The R&S[®]NRPC calibration kits use the technology in the R&S[®]NRP thermal sensors. The display of the RF power measurand takes place here entirely in the sensor all the way through the numerical measurement result. The R&S[®]NRP2 base unit is used only to set the sensor parameters and to display the measured value computed in the sensor. In this manner, any influence of the power meter base unit on the measured value is eliminated for the R&S[®]NRPC calibration kits. All of the necessary correction factors including the S-parameters for the reference attenuator ② are saved in the power standard's data memory ①.

Note: *In the R&S[®]NRPC calibration kits, the power standards contain all of the necessary data (correction and characteristic data).*

Information about the R&S[®]NRVC Calibration Kit

The R&S[®]NRVC calibration kit is a discontinued product. The following successor product is the R&S[®]NRPC18 calibration kit. The R&S[®]Recal+ software supports still the use of the R&S[®]NRVC calibration kit.

The R&S[®]NRVC calibration kit is based on the technology used in the R&S[®]NRV thermal sensors. They convert the supplied RF power into an analog voltage that is made available on the interface to the base unit. Following digitization and numerical correction, the base unit computes the RF power measurand. The correction factors that are used and their uncertainties are stored in the power standard's data memory. The equivalent reflection coefficients for the test port and the S-parameters for the reference attenuator are saved in separate files on the storage medium.

Information and Instructions on Calibration

Warm-Up Time for Devices under Test (DUTs)

For the sensors in the R&S[®]NRV and R&S[®]URV5 family, it is adequate to wait for two minutes after connection to the R&S[®]NRVD.

The sensors in the R&S[®]NRP and R&S[®]FSH family require a warm-up time of at least one hour after startup to attain their operating temperature. If it is frequently necessary to calibrate a series of sensors, let the uncalibrated sensors warm up while calibration is being performed on another one. In this application, they can be connected either to a multichannel R&S[®]NRP2 (option R&S[®]NRP-B2 and R&S[®]NRP-B5) or to a PC, preferably via the four-channel R&S NRP-Z5 USB sensor hub (material number 1146.7740.02).

Simply connecting the sensor to the PC is not sufficient for warm-up; instead, the sensor processor, which is the main source of heat for the sensor, must be placed in a typical operating state. For this to occur, the sensor must be recognized by Windows after it is connected and properly numbered (entered in the Windows device manager in the USB controller device group).

For numbering purposes, Windows always needs the associated device drivers that R&S provides with the **R&S[®]NRP Toolkit** software. This software is supplied with all R&S NRP sensors and can also be obtained from the Rohde & Schwarz website. For proper numbering of a sensor, **R&S[®]NRP Toolkit** must be installed prior to connecting the sensor for the first time.

Reflection Measurement

A sensor's reflection must always be measured from two perspectives. On the one hand, it is an important device property. On the other hand, reflection data in complex notation can be used to reduce the measurement errors resulting from mismatching during calibration of absolute accuracy (see section "Checking the Absolute Accuracy"). Reflection measurement is supported by the **R&S[®]ZVX_RECAL** additional program in conjunction with selected network analyzers from Rohde & Schwarz. In the appendix under *Measurements on a Separate Measurement Setup* in the *Reflection* section, methods are described for integrating reflection data from other network analyzers into the **R&S[®]Recal+** software.

Calibration of Absolute Accuracy

Refreshing the Device under Test's Data Set

When absolute accuracy is checked, the DUT's power reading is compared with that of a power standard over the DUT's entire frequency range. A tolerance test that is performed automatically by the **R&S[®]Recal+** software provides an indication of whether the sensor can be considered to comply with the specifications at the time point of delivery at the individual frequency points.

In order to ensure compliance with specifications for the following calibration interval, it is necessary for most sensors to also readjust the saved correction factors (calibration data) so that the errors that are measured compared to the power standard will disappear. This can be achieved in a subsequent measurement. Devices under test calibrated/adjusted in this manner reliably conform to the uncertainties specified in the data sheet.

A few sensors are specified such that the compliance with specifications is basically ensured if the tolerance limits used in calibration of absolute accuracy are met. In this case, it is not necessary to rewrite the correction factor memory (nor is it possible). In Table 1-4 to Table 1-7, these sensor types are indicated accordingly in the Absolute accuracy / Adjustment column.

Gamma Correction

Correction of the mismatch between the device under test and the power standard (Γ correction for short) generally reduces the influence of the mismatch by an order of magnitude. This correction is recommended in all cases, and it is even mandatory for some sensor types. These sensors are designated accordingly in Table 1-4 to Table 1-7. Γ correction is easy to activate via the user interface of the **R&S® Recal+** software, but it does require the availability of reflection values for the device under test in complex notation. Reflection measurement is supported by the **R&S® ZVX_RECAL** additional program in conjunction with selected network analyzers from Rohde & Schwarz.

R&S® NRP-Z Sensors with Attenuator

Calibration is different with the R&S® NRP-Z22, -Z23, -Z24 and -Z92 sensors which consist of a power sensor with an attenuator connected to the input. The attenuator is treated as a connectable S-parameter device for which separate correction factors are present in the data memory for the sensor. When these sensors are calibrated, the correction factors for the power sensor as well as for the attenuator must be refreshed if the uncertainties specified for the combination thereof are to be in conformance after the calibration.

Like all of the other R&S® NRP sensors, calibration of the power sensors is supported by the **R&S® Recal+** software. However, calibration of the attenuators is not supported. Since the risk of significant measurement errors is much higher compared to power calibration, this should be handled only by experienced personnel using suitable measurement setups. The section *S-parameter file for sensors with attenuators* (see appendix under *Measurements on a Separate Measurement Setup*) contains further details.

Insight into whether the existing calibration values for the attenuator are roughly correct can be obtained with a check measurement supported by the **R&S® Recal+** software on the power sensor with the attenuator screwed on.

Diode Sensors in the R&S® NRV and R&S® URV5 Families

Some of these sensors require a power level of less than 10 μ W for calibration of absolute accuracy. Accordingly, it is necessary to connect the reference attenuator ② to the output of the power standard to reduce the power level.

Linearity Calibration

For most DUTs, calibration of the linearity is used only to check that the sensor is functioning properly. This means that the check for compliance with tolerance limits that is performed by the **R&S® Recal+** software is fully adequate. In such cases, there is no need to refresh the set of correction factors (nor is it possible). The relevant sensors are designated accordingly in Table 1-4 to Table 1-7 in the Linearity/Adjustment column.

Information about the Supported Sensors

Table 1-4 Sensors supported by the R&S® NRVC and R&S® NRPC18 calibration kits

Type (model) R&S® ...	Calibration function					Frequency range, DUT (generator)
	Absolute accuracy		Linearity		Γ correction Mandatory	
	Adjustment	Check	Adjustment	Check		
NRP8S(N)	✓	✓	-	✓	-	10 MHz to 8 GHz
NRP18S(N)	✓	✓	-	✓	-	10 MHz to 18 GHz
FSH-Z1	✓	✓	-	✓	-	10 MHz to 8 GHz
FSH-Z18	✓	✓	-	✓	-	10 MHz to 18 GHz
NRP-Z11	✓	✓	-	✓	-	10 MHz to 8 GHz
NRP-Z21/-Z22/-Z23/-Z24	✓	✓	-	✓	-	10 MHz to 18 GHz
NRP-Z211	✓	✓	-	✓	-	10 MHz to 8 GHz
NRP-Z221	✓	✓	-	✓	-	10 MHz to 18 GHz
NRP-Z51 (02, 62)	✓	✓	-	✓	-	10 MHz to 18 GHz
NRP-Z51 (03)	✓	✓	-	✓	✓	10 MHz to 18 GHz
NRP-Z81	✓	✓	-	✓	✓	50 MHz to 18 GHz
NRP-Z91 (02, 04)	✓	✓	-	✓	-	9 kHz to 6 GHz
NRP-Z91 (08)	-	✓	-	✓	-	10 MHz to 8 GHz
NRP-Z92	✓	✓	-	✓	-	9 kHz to 6 GHz
NRV-Z1/-Z2	✓	✓	✓	✓	-	10 MHz to 18 GHz
NRV-Z4/-Z5	✓	✓	✓	✓	-	100 kHz to 6 GHz
NRV-Z7/-Z8	✓	✓	✓	✓	-	10 MHz to 13 GHz
NRV-Z31/-Z32/-Z33	-	✓	-	✓	-	30 MHz to 6 GHz
NRV-Z51 (02, 04)	✓	✓	✓	✓	-	10 MHz to 18 GHz
NRV-Z51 (06)	✓	✓	✓	✓	-	1 kHz to 6 GHz
NRV-Z53/-Z54	✓	✓	✓	✓	-	10 MHz to 18 GHz
URV5-Z2 (02, 05)	-	✓	-	✓	-	9 kHz to 3 GHz
URV5-Z2 (04)	-	✓	-	✓	-	9 kHz to 1 GHz
URV5-Z2 (55, 56)	-	✓	-	✓	-	9 kHz to 2 GHz
URV5-Z4 (02, 05)	-	✓	-	✓	-	100 kHz to 3 GHz
URV5-Z4 (04)	-	✓	-	✓	-	100 kHz to 2 GHz
URV5-Z4 (55, 56)	-	✓	-	✓	-	100 kHz to 2 GHz
URV5-Z5 (55)	✓	✓	✓	✓	-	10 MHz to 18 GHz
URV5-Z7	-	✓	-	✓	-	20 kHz to 1 GHz
URY-Z2	-	✓	-	✓	-	9 kHz to 2 GHz
URY-Z4	-	✓	-	✓	-	100 kHz to 2 GHz
URY-Z7	-	✓	-	✓	-	20 kHz to 1 GHz

Table 1-5 Sensors supported by the R&S® NRPC33 calibration kit

Type (model) R&S® ...	Calibration function					Frequency range, generator
	Absolute accuracy		Linearity		Γ correction Mandatory	
	Adjustment	Check	Adjustment	Check		
NRP33S(N)	✓	✓	-	✓	✓	10 MHz to 33 GHz
NRP-Z31	✓	✓	-	✓	✓	10 MHz to 33 GHz
NRP-Z52 (02, 62)	✓	✓	-	✓	✓	10 MHz to 33 GHz
NRP-Z52 (18)	✓	✓	-	✓	✓	10 MHz to 18 GHz
NRV-Z6	✓	✓	✓	✓**	✓	50 MHz to 26.5 GHz
NRV-Z52	✓	✓	✓	✓	✓	10 MHz to 26.5 GHz

Table 1-6 Sensors supported by the R&S® NRPC40 calibration kit

Type (model) R&S® ...	Calibration function					Frequency range, generator
	Absolute accuracy		Linearity		Γ correction Mandatory	
	Adjustment	Check	Adjustment	Check		
NRP-Z41	✓	✓	-	✓	✓	50 MHz to 40 GHz
NRP-Z55	✓	✓	-	✓	✓	10 MHz to 40 GHz
NRP-Z85	✓	✓	-	✓	✓	50 MHz to 40 GHz
NRV-Z15	✓	✓	✓	✓**	✓	50 MHz to 40 GHz
NRV-Z55	✓	✓	✓	✓	✓	10 MHz to 40 GHz

Table 1-7 Sensors supported by the R&S® NRPC50 calibration kit

Type (model) R&S® ...	Calibration function					Frequency range, generator
	Absolute accuracy		Linearity		Γ correction Mandatory	
	Adjustment	Check	Adjustment	Check		
NRP-Z61	✓	✓	-	✓	✓	50 MHz to 50 GHz
NRP-Z56	✓	✓	-	✓	✓	10 MHz to 50 GHz
NRP-Z86 (40)	✓	✓	-	✓	✓	50 MHz to 40 GHz
NRP-Z86 (44)	✓	✓	-	✓	✓	50 MHz to 44 GHz

** Calibration at 500 MHz necessary on separate measurement setup; not supported by the R&S® NRVC-B2

2 Putting into Operation

Unpacking the Unit

Check the delivery to ensure that it is complete and that there are no signs of damage. If any damage is present, inform the carrier immediately and keep the packaging to support any subsequent claims.

R&S®NRPC18 and R&S®NRPC18-B1

The R&S®NRPC18 calibration kit is supplied together with the R&S®NRPC18-B1 option in a storage case (Fig. 2-1 and Table 2-1).



Fig. 2-1 R&S®NRPC18 calibration kit

Table 2-1 Individual parts in the R&S®NRPC18 calibration kit

Item no.	Designation	Material number
①	Power standard	1418.0948.02
②	20 dB reference attenuator	1109.0898.00
③	CD with manual, program and data	1109.0769.00
④	Microwave connecting cable N (male) – N (male)	1306.4620.00
⑱	Adapter N (male) to BNC (male)	0351.7286.00
⑥	Precision 50 Ω termination	1418.1109.02
⑳	Adapter cable for connecting R&S®FSH-Z... sensors to the R&S®NRP (not shown)	1155.4940.00
㉓	Torque wrench (not shown)	1311.8242.04
㉔	Option: R&S®NRPC18-B1 verification kit	1418.1044.03

R&S®NRPC33 and R&S®NRPC33-B1

The R&S®NRPC33 calibration kit is supplied together with the R&S®NRPC33-B1 option in a storage case (Fig. 2-2 and Table 2-2).



Fig. 2-2 R&S®NRPC33 calibration kit

Table 2-2 Individual parts in the R&S®NRPC33 calibration kit

Item no.	Designation	Material number
①	Power standard	1418.0660.02
②	20 dB reference attenuator	1418.0731.00
③	CD with manual, program and data	1109.0769.00
④	Microwave connecting cable PC2.92 (male) – PC2.92 (male)	1159.6602.02
②①	Replacement adapter PC2.4 (male) – PC3.5 (female) for the test port	1418.0902.00
②②	Adapter for linearity N (male) – SMA (female)	4012.5837.00
②③	Torque wrench	1311.8213.02
②④	Option: R&S®NRPC33-B1 verification kit	1418.0683.02

R&S®NRPC40 and R&S®NRPC40-B1

The R&S®NRPC40 calibration kit is supplied together with the R&S®NRPC40-B1 option in a storage case (Fig. 2-3 and Table 2-3).



Fig. 2-3 R&S®NRPC40 calibration kit

Table 2-3 Individual parts in the R&S®NRPC40 calibration kit

Item no.	Designation	Material number
①	Power standard	1159.6825.00
②	20 dB reference attenuator	1159.6654.00
③	CD with manual, program and data	1109.0769.00
④	Microwave connecting cable PC2.92 (male) – PC2.92 (male)	1159.6602.00
②①	Replacement adapter PC2.4 (male) – PC2.92 (female) for the test port	1418.0919.00
②②	Adapter N (male) – SMA (female)	4012.5837.00
②③	Torque wrench	1311.8213.02
②④	Option: R&S®NRPC40-B1 verification kit	1159.6819.02

R&S®NRPC50 and R&S®NRPC50-B1

The R&S®NRPC50 calibration kit is supplied together with the R&S®NRPC50-B1 option in a storage case (Fig. 2-4 and Table 2-4).



Fig. 2-4 R&S®NRPC50 calibration kit

Table 2-4 Individual parts in the R&S®NRPC50 calibration kit

Item no.	Designation	Material number
①	Power standard	1159.6725.02
③	CD with manual, program and data	1109.0769.00
④	Microwave connecting cable PC1.85 (male) - PC1.85 (male)	1159.6619.00
⑳	Replacement adapter PC2.4 (male) – PC2.4 (female) for the test port	1418.0925.00
㉒	Adapter N (male) – PC2.4 (female)	1159.6919.00
㉓	Torque wrench	1311.8213.02
㉔	Option: R&S®NRPC50-B1 verification kit	1159.6890.02

R&S® NRVC-B2

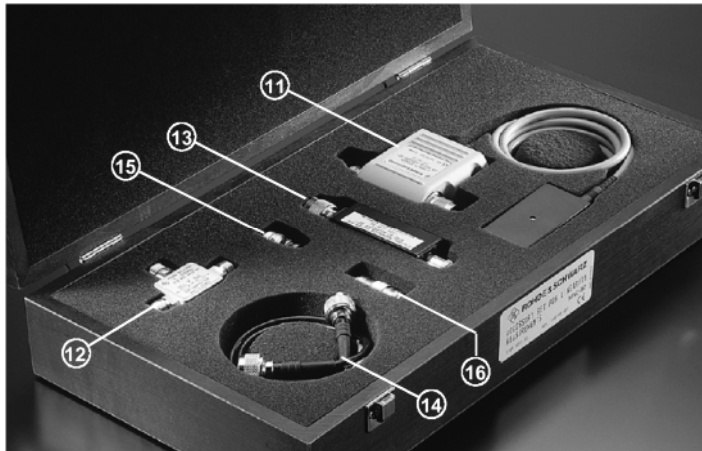

Fig. 2-5 R&S® NRVC-B2 accessory set

Table 2-5 Individual parts in the R&S® NRVC-B2 accessory set

Item no.	Designation	Material number
①①	Linearity standard	1109.1407.02
①②	Power splitter	0800.6612.52
①③	50 MHz harmonics filter	1109.1288.00
①④	Connecting cable 2 × N (male)	1109.1388.00
①⑤	N (female) to BNC (male) adapter	0541.8030.00
①⑥	N (female) to N (female) adapter	0092.6700.00

Additional Hardware Requirements

Several additional devices that are not included in the delivery are required in order to perform calibrations:

Required devices for operation of an R&S®NRPC and R&S®NRVC:

- **Controller** (PC) with IEC/IEEE bus interface from National Instruments
- **Generator for calibration of absolute accuracy**
- **Vector network analyzer for calibration of matching**
- **Calibration kit for calibration of network analyzer**
- **R&S®NRP2 power meter with options B1 and B2, respectively**
- **R&S®NRVD dual-channel power meter** (for calibrating sensors in the R&S®NRV-Z and R&S®URV5-Z series)

The following sections provide detailed descriptions of the devices listed above.

Devices for the R&S®NRPC and R&S®NRVC Calibration Kit

Controller

The entire calibration procedure, i.e. recording measured values, setting the generators and reading from and writing to the calibration data memory, is remote-controlled from a PC. The hardware requirements (clock frequency, RAM, hard disk space) are not critical; the operating system must be Microsoft Windows® 7.

Also required is a National Instruments IEC/IEEE bus interface which can run under the installed operating system and act as the interface to the measuring instruments. Before using the calibration kit for the first time, test the installation of the IEC/IEEE bus card with the tools supplied by the manufacturer (*ibconf*, *ibdiag*, etc.).

R&S®NRP-ZK6 interface cable

For the R&S®NRPxxS/SN power sensors an R&S®NRP-ZK6 (Table 2-6) interface cable is mandatory.

Table 2-6 6-pole Interface Cable for R&S®NRPxxS/SN power sensors

Type	Option	Material number
R&S®NRP-ZK6	length: 1.5 m	1419.0664.02
	length: 3 m	1419.0664.03
	length: 5 m	1419.0664.04

Generators for Calibration of Absolute Accuracy

The required characteristics depend on the frequency measurement range and the power measurement range of the DUT (Table 1-4 to Table 1-7). The generator that is selected must cover the entire frequency range. Table 2-7 shows a selection of generators from the current R&S product line that are recommended for operation of the R&S[®]NRVC or R&S[®]NRPC calibration kit. This selection makes it possible to cover a wide frequency range with only a few types. Current instruments that are not listed such as the R&S[®]SMC100A or R&S[®]SMB100A in the 3 GHz version are generally also supported.

Calibration of sensors with a frequency range up to 50 GHz is currently possible only with the E8257D generator from the company Agilent when equipped with the appropriate options.

Older generators supported by the **R&S[®]Recal+** software are listed in Table 2-9.

Table 2-7 Supported generators in the current product range

f range, DUT \Rightarrow	≥ 9 kHz to ≤ 3 GHz	≥ 9 kHz to ≤ 6 GHz	≥ 10 MHz to ≤ 18 GHz	≥ 10 MHz to ≤ 33 GHz	≥ 10 MHz to ≤ 40 GHz	≥ 10 MHz to ≤ 50 GHz
Generator type + options \Downarrow						
R&S [®] SMA100A + option -B106	✓	✓				
R&S [®] SMB100A + option -B106	✓	✓				
R&S [®] SMB100A + options -B120, -B31 *			✓			
R&S [®] SMB100A + options -B140, -B32			✓	✓	✓	
R&S [®] SMF100A + options -B144, -B2, -B27, + option -B34			✓	✓	✓	
Agilent E8257D + options -550, -1EU, -1E1			✓	✓	✓	✓

* The option R&S[®]SMB-B31 is necessary only for calibration of the R&S[®]NRV-Z53/-Z54 power sensors.

Table 2-8 Ordering information for the generators in the current R&S product range

Type	Material number	Options		Material number for option
R&S [®] SMA100A	1400.0000.02	6 GHz	R&S [®] SMA-B106	1405.0809.02
R&S [®] SMB100A	1406.6000.02	6 GHz	R&S [®] SMB-B106	1407.2909.02
		20 GHz	R&S [®] SMB-B120 R&S [®] SMB-B31	1407.2209.02 1407.1260.02
		40 GHz	R&S [®] SMB-B140 R&S [®] SMB-B32	1407.2309.02 1407.1360.02
R&S [®] SMF100A	1167.0000.02	43.5 GHz	R&S [®] SMF-B144 R&S [®] SMF-B2 R&S [®] SMF-B27 R&S [®] SMF-B34	1167.7204.03 1167.4005.02 1167.5776.02 1415.2404.02

Table 2-9 Supported generators that are no longer available

f range, DUT ⇒	≥ 9 kHz to ≤ 3 GHz	≥ 9 kHz to ≤ 6 GHz	≥ 10 MHz to ≤ 18 GHz	≥ 10 MHz to ≤ 26.5 GHz	≥ 10 MHz to ≤ 33 GHz	≥ 10 MHz to ≤ 40 GHz
Generator type ↓						
R&S®SML03, R&S®SMV03	✓					
R&S®SME06, R&S®SMT06	✓	✓				
R&S®SMR20			✓			
R&S®SMR27/30			✓	(✓)		
R&S®SMR40			✓	(✓)		(✓) *
R&S®SMP02/22			✓			
R&S®SMP03			✓	✓		
R&S®SMP04			✓	✓	✓	(✓) *
R&S®SWM02/05			✓			
R&S®SMGL	Linearity measurements with the R&S®NRVC-B2					
HP8116A	Linearity measurements with the R&S®NRVC-B2					

* Only suitable for calibration R&S®NRV-Z6/-Z15.

Vector Network Analyzers for Calibration of Matching

The required characteristics are focused primarily on the frequency range and connector used by the DUT (Table 1-4 to Table 1-7). Its lower frequency limit is less important since R&S sensors at least do not exhibit any significant changes in the matching at lower frequencies. Accordingly, a standard lower frequency limit of 10 MHz can be assumed when selecting an appropriate analyzer.

Table 2-10 shows a group of network analyzers selected based on this perspective where the objective is to cover a very large frequency range with very few types. Only these analyzers along with those listed in Table 2-11 which are no longer sold are currently supported by the R&S® *Recal+* calibration software and the R&S® *ZVX_RECAL* additional program. Of course, it is also possible to use other network analyzers. However, the user must take care to ensure that the appropriate frequency points are measured and the calibration results are made available in the necessary file format (see appendix under *Measurements on a Separate Measurement Setup* in the *Matching* section, *Separate recording of the matching*).

For calibration of the supported network analyzers, the calibration kits listed in Table 2-13 are recommended. For sensors with a 3.5 mm connector, the R&S® ZV-Z235 standard kit with a frequency range of 24 GHz is not adequate. Instead, the "E" version must be used. It is specified for use up to 33 GHz.

Note: For the sake of traceability and higher accuracy, German Accreditation Body (DAKks) calibration is recommended at the laboratory D-K-15195-01-00 operated by Rohde & Schwarz.
The German Accreditation Body calibration must generally be ordered separately. It is included with the item only for the R&S® ZV-Z235E and R&S® NRVC/NRPC calibration kits.

Table 2-10 Supported network analyzers in the current product range

Type	R&S® ... calibration kit used for power calibration			
	NRVC/NRPC18	NRPC33	NRPC40	NRPC50
R&S® ZVB20	✓			
R&S® ZVA24	✓			
R&S® ZVA40	✓	✓	✓	
R&S® ZVA50	✓	✓	✓	✓
R&S® ZVA67	✓	✓	✓	✓
R&S® ZNB8	✓			
R&S® ZNB20	✓			
R&S® ZNB40	✓	✓	✓	

Table 2-11 Supported network analyzers which are no longer available

Type	R&S® ... calibration kit used for power calibration			
	NRVC/NRPC18	NRPC33	NRPC40	NRPC50
R&S® ZVM	✓			
R&S® ZVK	✓	✓	✓	

Table 2-12 Ordering information for network analyzers

Type	Material number	Comments
R&S®ZVB20	1145.1010.20	Versions with four ports are also supported
R&S®ZVB20	1145.1010.23	
R&S®ZVA24	1145.1110.24	
R&S®ZVA40	1145.1110.40	
R&S®ZVA50	1145.1110.50	
R&S®ZVA67	1305.7002.02	
R&S®ZNB8	1311.6010.42	
R&S®ZNB20	1311.6010.62	
R&S®ZNB40	1311.6010.72	

Table 2-13 Recommended calibration kits for network analyzers

Connector	N-50 Ω	3.5 mm	2.92 mm	2.4 mm
Frequency range	10 MHz to 18 GHz	10 MHz to 33 GHz	10 MHz to 40 GHz	10 MHz to 50 GHz
Type	R&S®ZV-Z270	R&S®ZV-Z235E	R&S®ZV-Z229	R&S®ZV-Z224

Table 2-14 Ordering information for calibration kits

Type	Material number	Comments
ZV-Z270	5011.6536.02	German Accreditation Body (DAkkS) calibration must be ordered separately
ZV-Z235E	5011.6707.02	German Accreditation Body (DAkkS) calibration included
ZV-Z229	5011.6559.02	German Accreditation Body (DAkkS) calibration must be ordered separately
ZV-Z224	5011.6565.02	German Accreditation Body (DAkkS) calibration must be ordered separately

Devices for the R&S[®] NRPC Calibration Kit

R&S[®] NRP2 Base Unit

For operation of the **R&S[®] Recal+** calibration software in conjunction with an R&S[®] NRPC power standard, an R&S[®] NRP2 dual-channel power meter is mandatory. This device also needs to be fitted with option R&S[®] NRP-B1, a 50 MHz test generator, so that a quick check of the sensors can be performed before calibration is started. In order for the **R&S[®] Recal+** calibration software to function properly, the appropriate firmware version must be installed in the R&S[®] NRP2. The firmware must be replaced if the displayed version number is less than the 07.11.

Table 2-15 Ordering information for the R&S[®] NRP2 power meter

Type	R&S [®] NRP2 Base unit	Option: R&S [®] NRP-B7 Sensor check source	Option: R&S [®] NRP-B2 2nd sensor input (B)	Option: R&S [®] NRP-B5 3 rd and 4th sensor inputs (C,D)
Material number	1144.1374.02	1144.1000.02	1146.8801.02	1146.9608.02

R&S[®] NRVD Dual-Channel Power Meter

For calibration of sensors in the R&S[®] NRV-Z and R&S[®] URV5-Z series, a base unit of the type R&S[®] NRVD is required (see *Operation of the R&S[®] NRVC Calibration Kit*).

The R&S[®] NRVD Dual-Channel Power Meter is a discontinued product.

Devices for the R&S®NRVC Calibration Kit

R&S®NRVD Dual-Channel Power Meter

The R&S®NRVD Dual-Channel Power Meter is a discontinued product.

For operation of the **R&S®Recal+** calibration software in conjunction with an NRVC calibration Kit, an R&S®NRVD dual-channel power meter is mandatory. It allows connection of the R&S®NRVC power standard and the R&S®NRVC-B2 linearity standard. The most recent calibration of the instrument should have been within the last 12 months. For calibration of the R&S®NRVD, the R&S®NRVD-S1 service kit is available. It allows complete calibration in only a few minutes in conjunction with a DC voltage calibrator.

If both absolute accuracy and linearity need to be calibrated, a second R&S®NRVD is highly recommended. A DUT from the R&S®NRV-Z or R&S®URV5-Z family is then connected to the first R&S®NRVD, and the reference sensors are operated on the second R&S®NRVD.

Note: <i>Since the R&S®NRVD power meter must also accommodate one of the two reference sensors, it is highly recommended when calibrating sensors in the R&S®NRV-Z or R&S®URV5-Z series to use a second R&S®NRVD. In this manner, it is not necessary to change sensors and to wait until the new sensor attains normal operating temperature.</i>

R&S®NRP2 Base Unit

In order to calibrate sensors in the R&S®NRP-Z and R&S®FSH-Z series, an R&S®NRP2 power meter with two channels is mandatory. In order for the **R&S®Recal+** calibration software to function properly, the appropriate firmware version must be installed in the R&S®NRP2. The firmware must be replaced if the displayed version number is less than the 07.11.

For further details, see the relevant section under *Operation of the R&S®NRPC Calibration Kit*.

Operation of the R&S®NRVC-B2 Calibration Kit

Generator for Calibration of Linearity

The R&S®NRVC-B2 accessory set allows linearity measurements for all DUTs that are calibrated at 50 MHz (Table 1-4 to Table 1-7). Two types of generators are supported for these measurements: The R&S®SMGL power signal generator and the HP8116A function generator. Unfortunately, however, neither of these generators is available any more. There are no restrictions on the use of the R&S®SMGL. However, with earlier HP8116A models, communications problems may occur on the IEC/IEEE bus. Tests should be performed to verify that the device is operating correctly. Malfunctions on the IEC/IEEE bus are not likely to impair measurement accuracy. For calibration of the R&S®NRP-Z and R&S®FSH-Z sensors, the HP8116A function generator does not quite reach 23 dBm, which is the upper power limit of the diode sensors; instead, it typically reaches only approx. 21 dBm. However, this is sufficient since only a check is being performed.

Power Calibration with the R&S[®]NRPC18 Calibration Kit

Fig. 2-6 to Fig. 2-14 show the measurement setups used for calibration of absolute accuracy with the R&S[®]NRPC18 calibration kit.

R&S[®] NRP Sensors up to 18 GHz

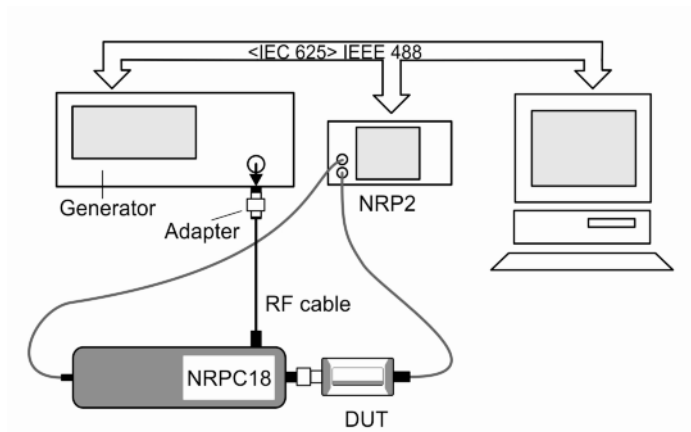

Fig. 2-6
Measurement setup for calibrating absolute accuracy for the R&S[®]NRP power meter family.

- For the R&S[®]NRPxxS/SN power sensors an R&S[®]NRP-ZK6 interface cable as well as an R&S[®]NRP2 power meter is mandatory
- Depending on the generator used, an adapter for connecting the RF cable may be required
- For calibration in conjunction with the R&S[®]NRVC calibration kit a base unit of the type R&S[®]NRVD is required.

R&S[®]FSH-Z1, -Z18

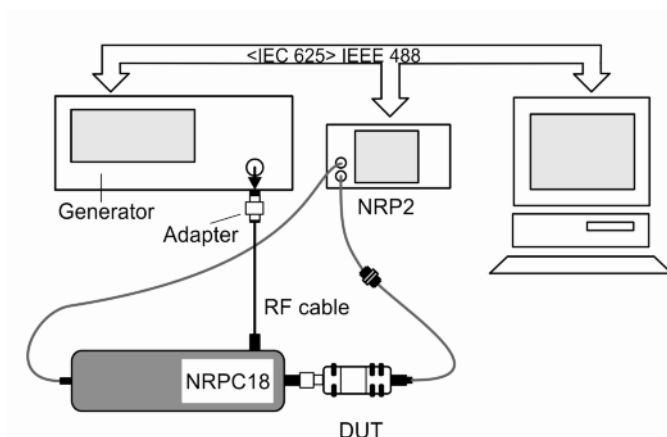

Fig. 2-7
Measurement setup for calibrating absolute accuracy for the R&S[®]FSH-Z1, -Z18.

- Adapter cable (20) is necessary for connecting the sensor to the R&S[®]NRP2
- Depending on the generator used, an adapter for connecting the RF cable may be required
- For calibration in conjunction with the R&S[®]NRVC calibration kit a base unit of the type R&S[®]NRVD is required.

R&S® NRV-Z2, -Z5, -Z8, -Z51

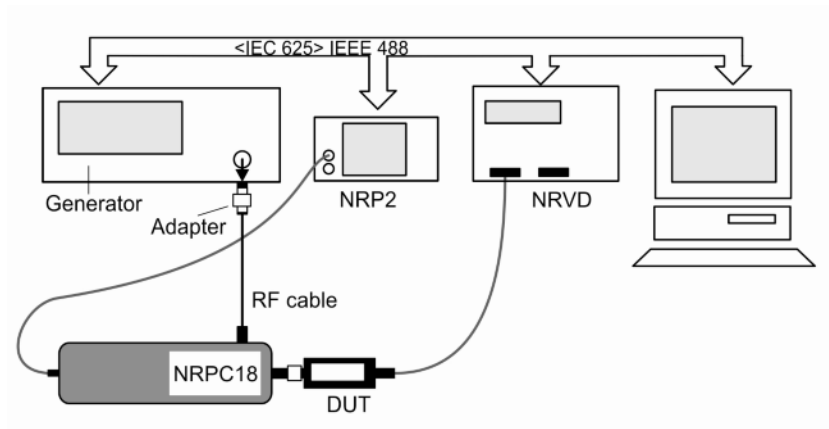

Fig. 2-8
Measurement setup for calibrating absolute accuracy for the R&S®NRV-Z2, -Z5, -Z8, -Z51.

- Depending on the generator used, an adapter for connecting the RF cable may be required
- The R&S®NRPC18 with the power standard must be configured as Meter2 in the Meter dialog box

R&S® NRV-Z32

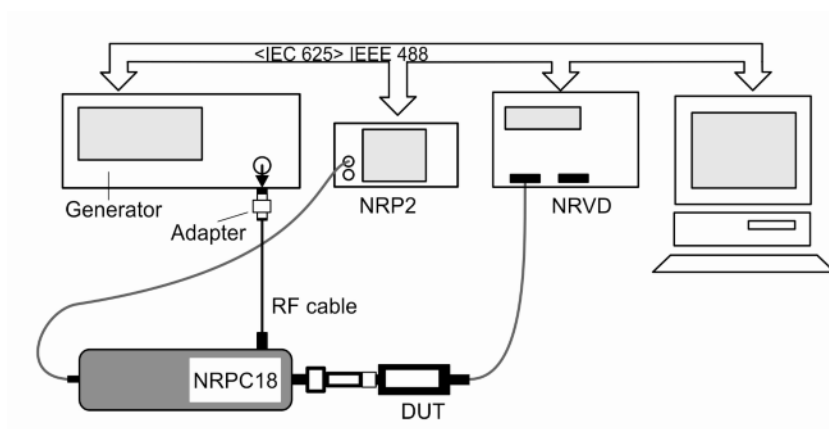

Fig. 2-9
Measurement setup for calibrating absolute accuracy for the R&S®NRV-Z32.

- The sensor is tested with the corresponding attenuator
- Depending on the generator used, an adapter for connecting the RF cable may be required
- The R&S®NRPC18 with the power standard must be configured as Meter2 in the Meter dialog box

R&S® NRV-Z33, -Z53, -Z54

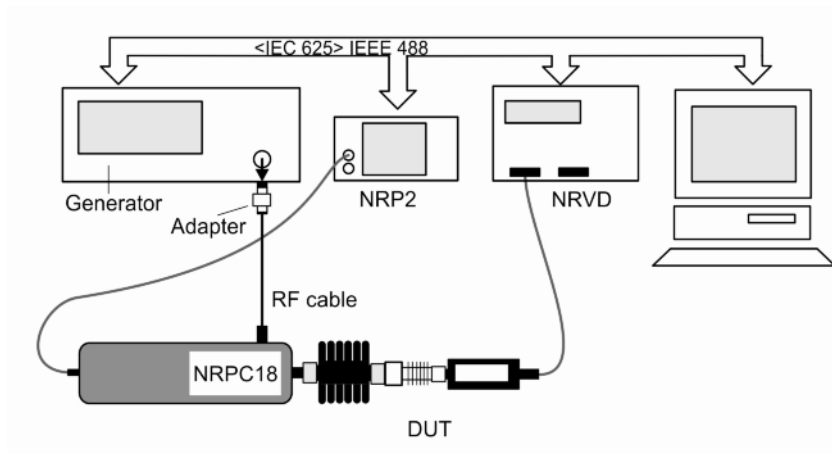

Fig. 2-10
Measurement setup for calibrating absolute accuracy for the R&S® NRV-Z33, -Z53, -Z54.

- The sensor is tested with the corresponding attenuator
- Depending on the generator used, an adapter for connecting the RF cable may be required
- The R&S® NRPC18 with the power standard must be configured as Meter2 in the Meter dialog box

R&S® NRV-Z1, -Z4, -Z7, -Z31

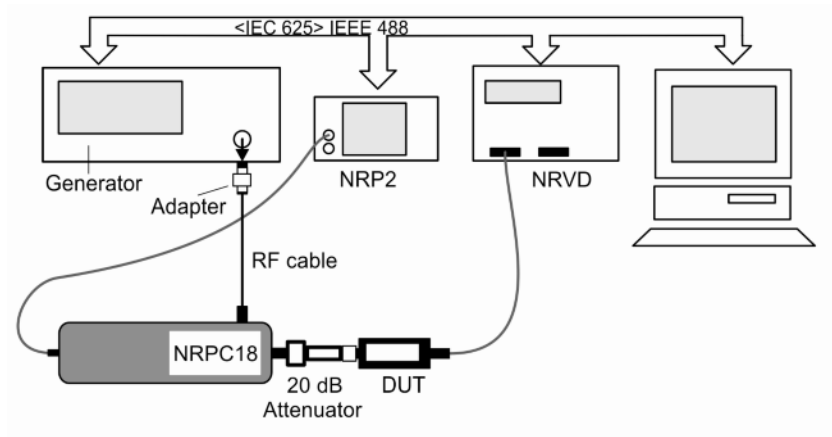

Fig. 2-11
Measurement setup for calibrating absolute accuracy for the R&S® NRV-Z1, -Z4, -Z7, -Z31.

- Reference attenuator ② is to be connected to the output of the power standard
- Depending on the generator used, an adapter for connecting the RF cable may be required
- The R&S® NRPC18 with the power standard must be configured as Meter2 in the Meter dialog box

R&S® URV5-Z2

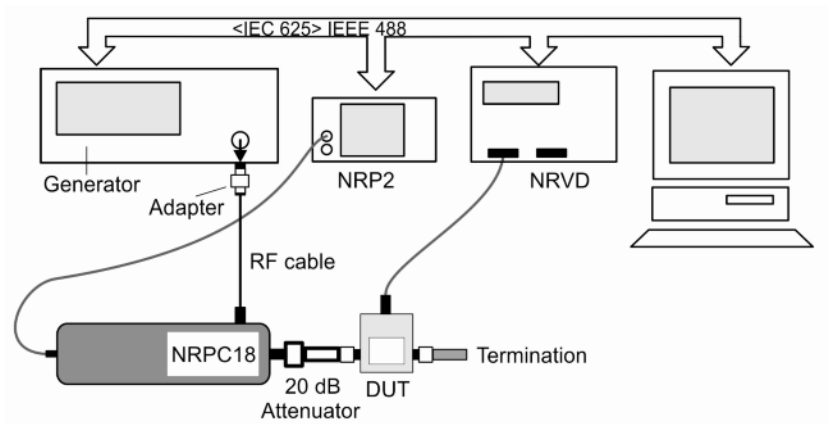

Fig. 2-12
Measurement setup for calibrating absolute accuracy for the R&S® URV5-Z2.

- Reference attenuator ② is to be connected to the output of the power standard
- The sensor must be terminated with precision termination ⑥
- The R&S® NRPC18 with the power standard must be configured as Meter2 in the Meter dialog box

R&S® URV5-Z4

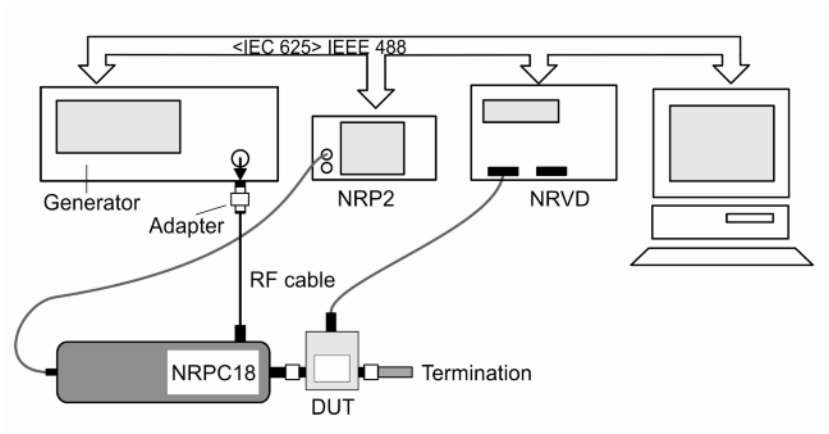

Fig. 2-13
Measurement setup for calibrating absolute accuracy for the R&S® URV5-Z4.

- Depending on the generator used, an adapter for connecting the RF cable may be required
- The R&S® NRPC18 with the power standard must be configured as Meter2 in the Meter dialog box

R&S® URV5-Z7

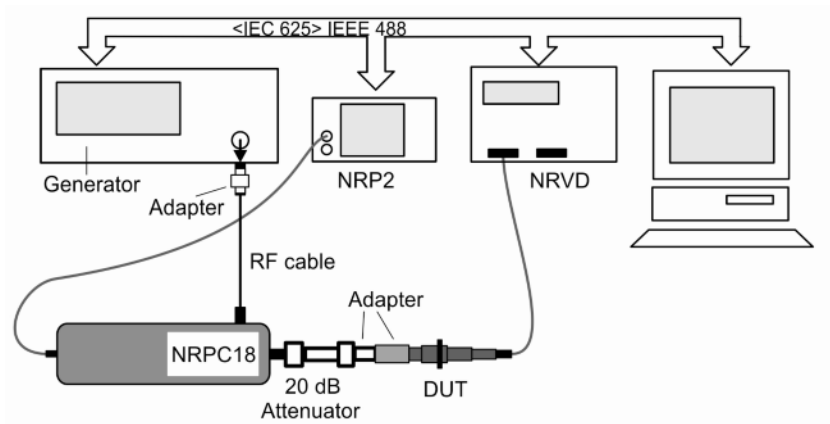

Fig. 2-14
Measurement setup for calibrating
absolute accuracy for the
R&S® URV5-Z7.

- Reference attenuator ② is to be connected to the output of the power standard
- The sensor must be connected via a 50 Ω adapter R&S® URV-Z50
- The adapter ⑱ for adapting the 50 Ω adapter to the reference attenuator has been included with the R&S® NRVC calibration kit since 1999
- Depending on the generator used, an adapter for connecting the RF cable may be required
- The R&S® NRPC18 with the power standard must be configured as Meter2 in the Meter dialog box

Power Calibration with the R&S® NRPC33 Calibration Kit

Fig. 2-15 to Fig. 2-17 show the measurement setups used for calibration of absolute accuracy with the R&S® NRPC33 calibration kit.

R&S® NRP Sensors up to 33 GHz

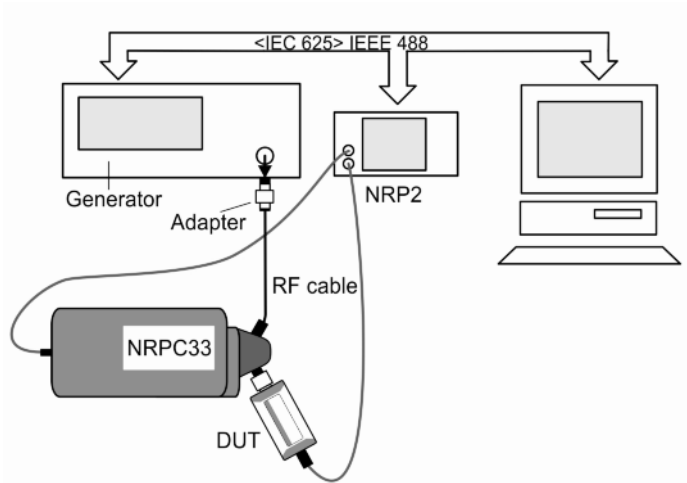

Fig. 2-15
Measurement setup for calibrating absolute accuracy for the R&S® NRP power meter family.

- For the R&S® NRPxxS/SN power sensors an R&S® NRP-ZK6 interface cable as well as an R&S® NRP2 power meter is mandatory
- Depending on the generator used, an adapter for connecting the RF cable may be required

R&S® NRV-Z52

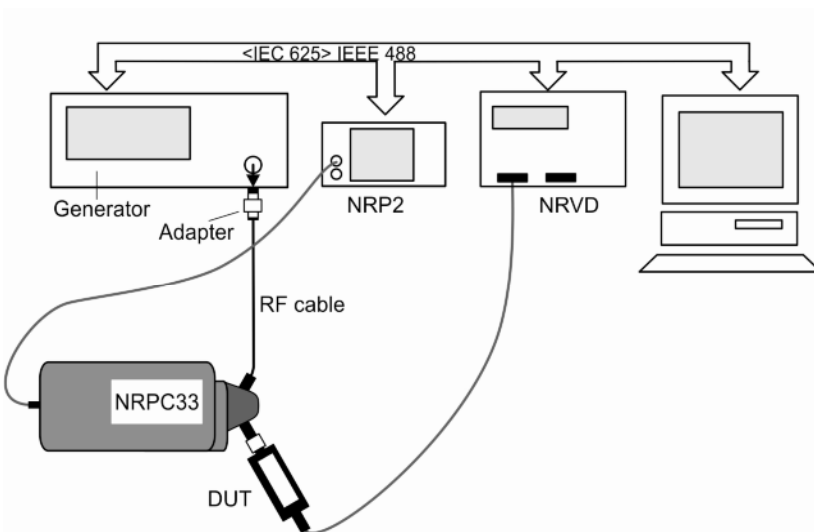

Fig. 2-16
Measurement setup for calibrating absolute accuracy for the R&S® NRV-Z52.

- The R&S® NRP2 with the power standard must be configured as Meter2 in the Meter dialog box
- Depending on the generator used, an adapter for connecting the RF cable may be required

R&S® NRV-Z6

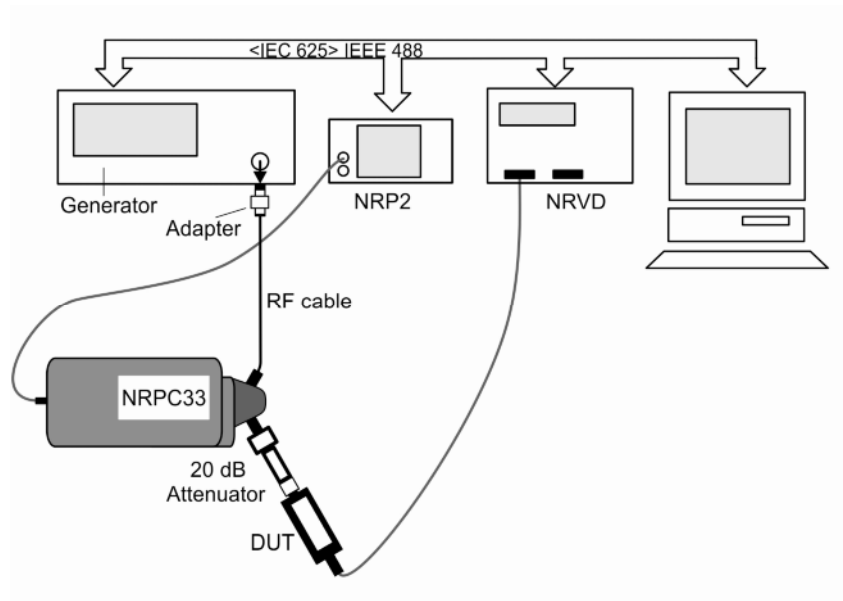

Fig. 2-17
Measurement setup for calibrating absolute accuracy for the R&S® NRV-Z6.

- Reference attenuator ② is to be connected to the output of the power standard
- The R&S® NRP2 with the power standard must be configured as Meter2 in the Meter dialog box
- Depending on the generator used, an adapter for connecting the RF cable may be required

Power Calibration with the R&S®NRPC40 Calibration Kit

Fig. 2-18 to Fig. 2-20 show the measurement setups used for calibration of absolute accuracy with the R&S®NRPC40 calibration kit.

R&S®NRP Sensors up to 40 GHz

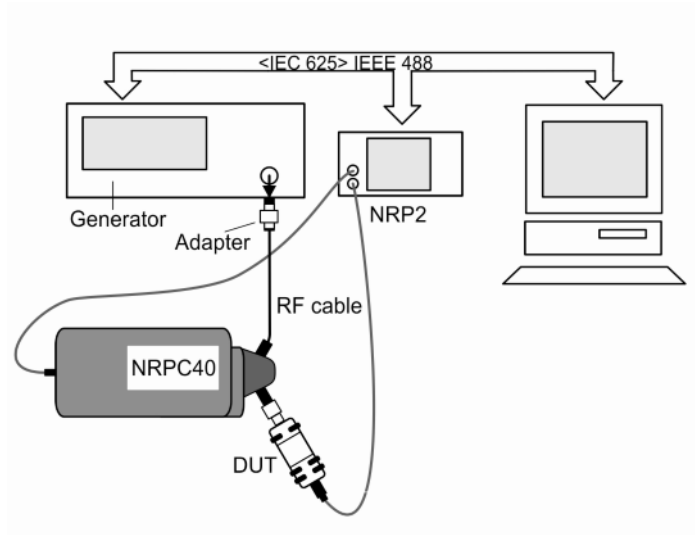

Fig. 2-18
Measurement setup for calibrating absolute accuracy for the R&S®NRP power meter family.

- Depending on the generator used, an adapter for connecting the RF cable may be required

R&S®NRV-Z55

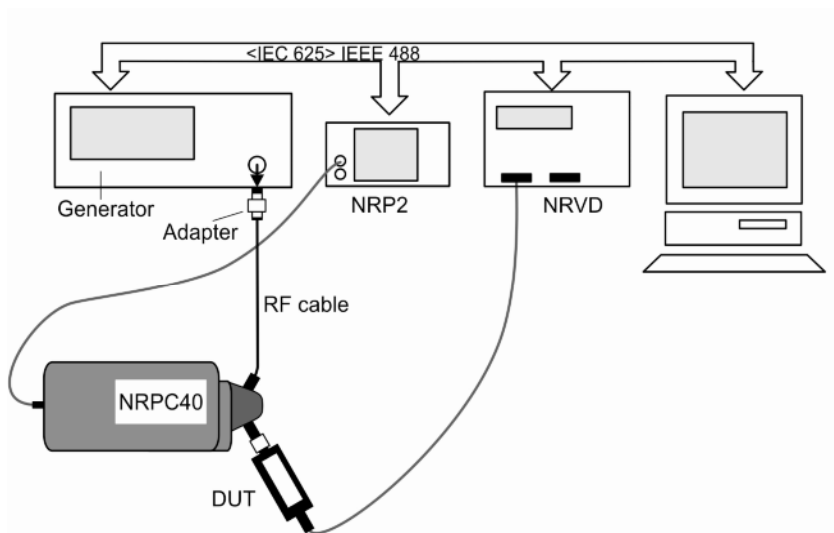

Fig. 2-19
Measurement setup for calibrating absolute accuracy for the R&S®NRV-Z55.

- The R&S®NRP2 with the power standard must be configured as Meter2 in the Meter dialog box
- Depending on the generator used, an adapter for connecting the RF cable may be required

R&S® NRV-Z15

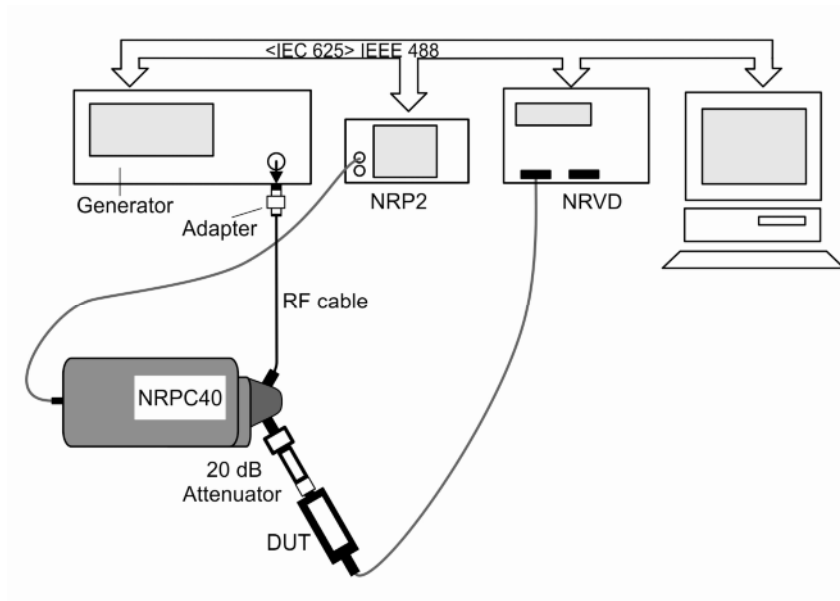

Fig. 2-20
Measurement setup for calibrating absolute accuracy for the R&S® NRV-Z15.

- Reference attenuator ② is to be connected to the output of the power standard
- The R&S® NRP2 with the power standard must be configured as Meter2 in the Meter dialog box
Depending on the generator used, an adapter for connecting the RF cable may be required

Power Calibration with the R&S[®]NRPC50 Calibration Kit

Fig. 2-21 shows the measurement setup used for calibration of absolute accuracy with the R&S[®]NRPC50 calibration kit.

R&S[®] NRP Sensors up to 50 GHz

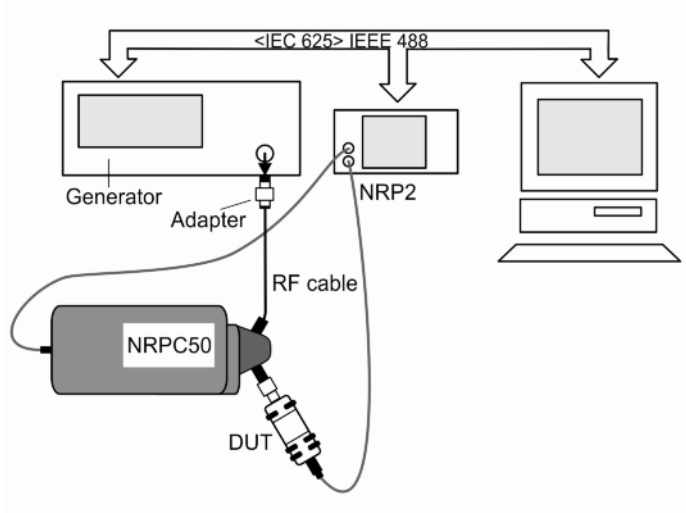

Fig. 2-21
Measurement setup for calibrating absolute accuracy for the R&S[®]NRP power meter family.

- Depending on the generator used, an adapter for connecting the RF cable may be required

Linearity Calibration with the R&S®NRVC-B2 Option

Fig. 2-22 to Fig. 2-28 show the measurement setups used for calibration of linearity with the R&S®NRVC-B2 accessory set.

When linearity is checked, the relative change in the power reading of the DUT is measured as a function of the input power based on the reference power used in the calibration of absolute accuracy. The test frequency is always 50 MHz; a specially calibrated coaxial voltage sensor ⁽¹¹⁾ is used as the linearity standard.

R&S®NRP Sensors

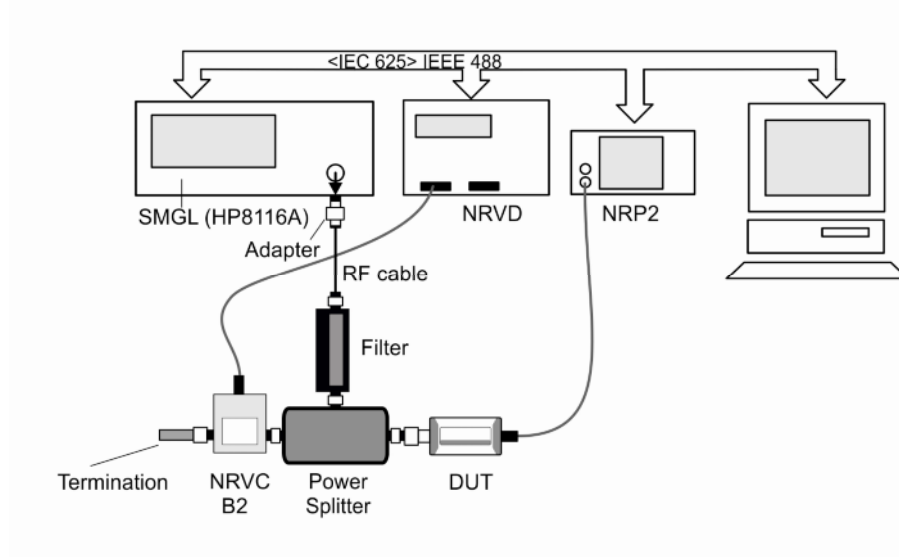

Fig. 2-22
Measurement setup for linearity calibration for R&S®NRP power meter family.

- For the R&S®NRPxxS/SN power sensors an R&S®NRP-ZK6 interface cable as well as an R&S®NRP2 power meter is mandatory
- Connection of DUT to the R&S®NRP2
- To allow connection of DUTs with 3.5 mm or 2.92 mm connectors, the R&S®NRPC33 and R&S®NRPC40 calibration kits include adapter ⁽²²⁾
- To allow connection of DUTs with a 2.4 mm connector, the R&S®NRPC50 calibration kit includes adapter ⁽²²⁾
- The R&S®NRVD with the linearity standard must be configured as Meter2 in the Meter dialog box
- If the HP8116A is used, adapter ⁽¹⁵⁾ is required in order to connect the RF cable. In this setup, the power of the HP8116A function generator does not quite reach 23 dBm, which is the upper power limit of the diode sensors; instead, it typically reaches only approx. 21 dBm. However, this is sufficient since only a check is being performed

R&S® FSH-Z1, -Z18

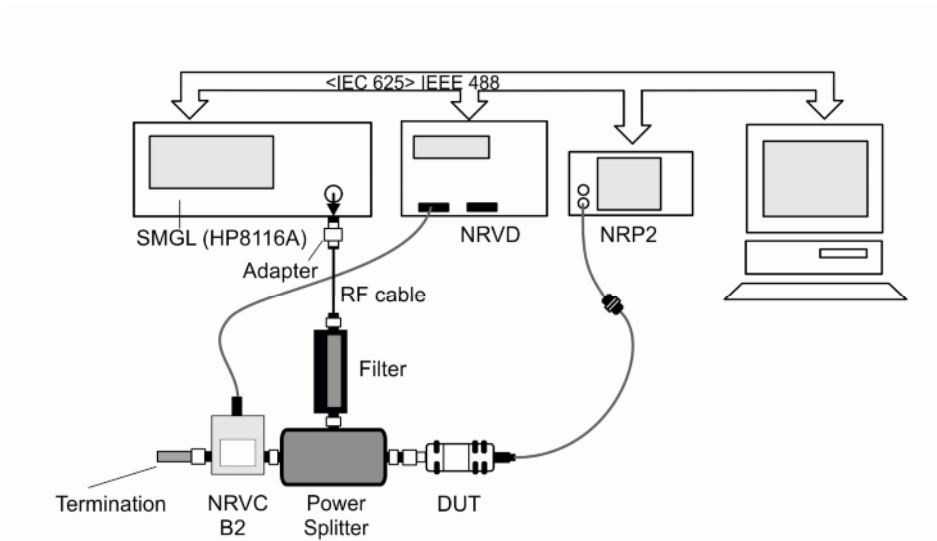

Fig. 2-23
Measurement setup for calibrating linearity for the R&S® FSH-Z1, -Z18.

- Connection of the sensor to the R&S® NRP2 requires adapter cable (20). As of 2004, this cable is included with the R&S® NRVC. For devices shipped before 2004, this cable is available as spare part no. 1155.4940.00
- The R&S® NRVD with the power standard must be configured as Meter2 in the Meter dialog box
- In this setup, the power of the HP8116A function generator does not quite reach 23 dBm, which is the upper power limit of the diode sensors; instead, it typically reaches only approx. 21 dBm. However, this is sufficient since only a check is being performed

R&S® NRV-Z1, -Z4, -Z7, -Z31, -Z51, -Z52, -Z55

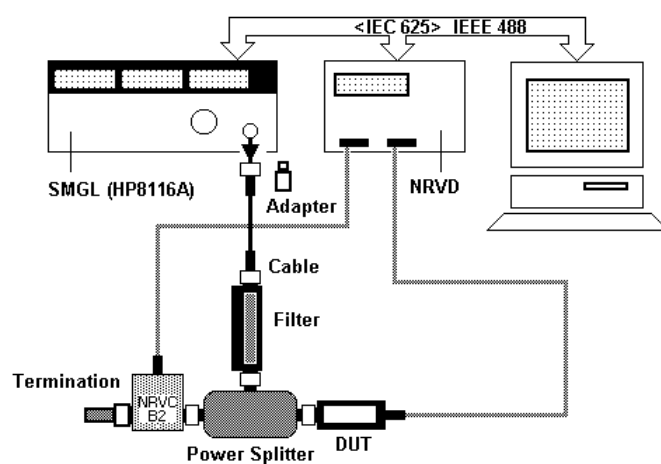

Fig. 2-24
Measurement setup for calibrating linearity for the R&S® NRV-Z1, -Z4, -Z7, -Z15, -Z31, -Z51, -Z52, -Z55.

- To allow connection of DUTs with 3.5 mm or 2.92 mm connectors, the R&S® NRPC33 and R&S® NRPC40 calibration kits include adapter (22)
- If the HP8116A is used, adapter (15) is required in order to connect the RF cable. In this setup, the power of the HP8116A function generator does not quite reach 23 dBm, which is the upper power limit of the diode sensors; instead, it typically reaches only approx. 21 dBm. However, this is sufficient since only a check is being performed

R&S® NRV-Z32, -Z33, -Z53, -Z54

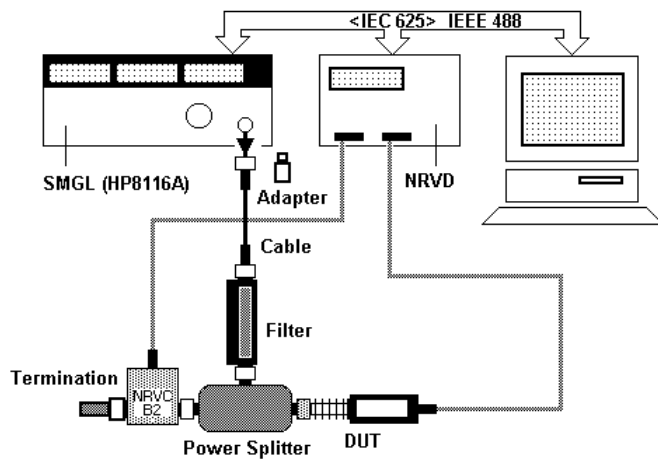

Fig. 2-25
Measurement setup for calibrating linearity for the R&S® NRV-Z33, -Z53, -Z54.

- The sensor must be connected to the power splitter without an attenuator connected
- If the HP8116A is used, adapter ⑮ is required in order to connect the RF cable

R&S® NRV-Z2, -Z5, -Z8

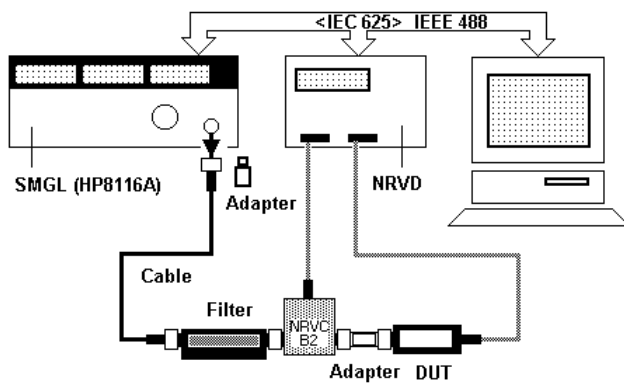

Fig. 2-26
Measurement setup for calibrating linearity for the R&S® NRV-Z2, -Z5, -Z8.

- Connect the sensor via adapter ⑯ to the linearity standard
- If the HP8116A is used, adapter ⑮ is required in order to connect the RF cable

R&S® URV5-Z7

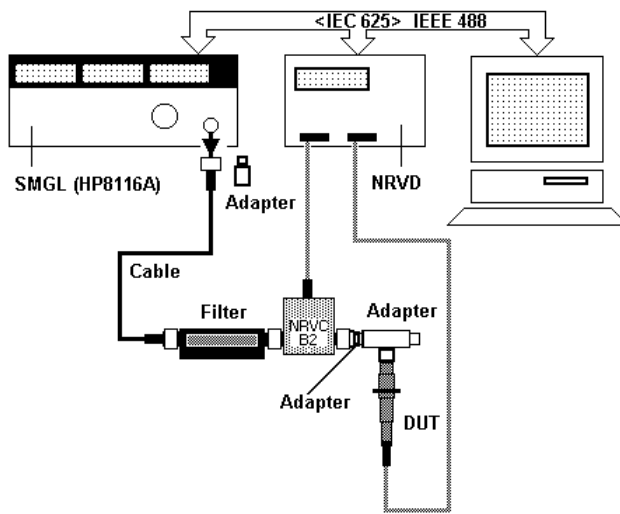

Fig. 2-27
Measurement setup for calibrating linearity for the R&S® URV5-Z7.

- A BNC feed-through adapter (part of the R&S® URV-Z6 accessory set) is required for adapting the RF probe
- The sensor is open-circuited on the output side, i.e. it is operated without being terminated
- If the HP8116A is used, adapter ⑮ is required in order to connect the RF cable

R&S® URV5-Z2, -Z4

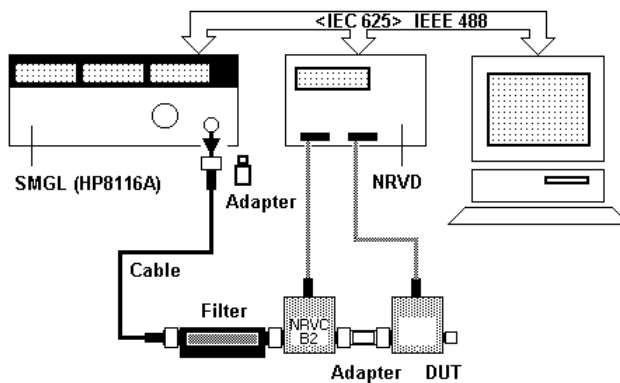

Fig. 2-28
Measurement setup for calibrating linearity for the R&S® URV5-Z2, -Z4.

- The sensor must be connected with the linearity standard via adapter ⑯ in all cases. A direct connection via the sensor's female connector is not permitted
- The sensor is open-circuited on the output side, i.e. it is operated without being terminated
- If the HP8116A is used, adapter ⑮ is required in order to connect the RF cable

3 Sensor Calibration

Preparation

Installing the R&S® *Recal+* Calibration Software on the Hard Disk

The R&S® *Recal+* software for the R&S® NRPC (R&S® NRVC) calibration kits is on the program CD ③ and must be installed on the controller's hard disk before the calibration kit is used for the first time. Installation is handled on an interactive basis by executing *RECAL+ <*>.exe* (e.g. *RECAL+ 3.03.00.exe*). The *Recal+* program group and the corresponding directory structure will be created automatically.

As part of the installation process, the software prompts for the calibration data for the R&S® NRVC calibration kit. If an R&S® NRVC calibration kit is present, it is possible to insert the CD-ROM with the calibration data ⑨ and select the **Calibration Data** directory on the data CD-ROM. However, it is also possible to retransfer or modify any of calibration data at a later point in time.

When using the R&S® NRPC calibration kit, this step can be skipped using "Cancel".

Installing the R&S® *ZVX_RECAL* Additional Program on the Hard Disk

The R&S® *ZVX_RECAL* additional program allows reflection measurements under program control using the R&S® *Recal+* software in conjunction with selected network analyzers from Rohde & Schwarz. It is also found on CD-ROM ③. Installation is handled interactively by executing the file *setup.exe*. After the program is successfully installed, the dialog box **Measurement with NRVC/NRPC** (after pressing the button ) should have the **Reflection / S Parameter** tab (Fig. 6-2). From there, the network analyzer and DUT are selected and the test program is launched.

Starting the Calibration Software

- Start the calibration software by double-clicking the following icon



on the desktop or the entry in the corresponding program group in the Windows Start menu.

Comprehensive help texts and a context-sensitive help function are provided for all important functions. They can be called by selecting the **Help** button. The information that is given supplements this manual which provides only a set of practical instructions for performing a calibration procedure without going into detail about the calibration software itself.

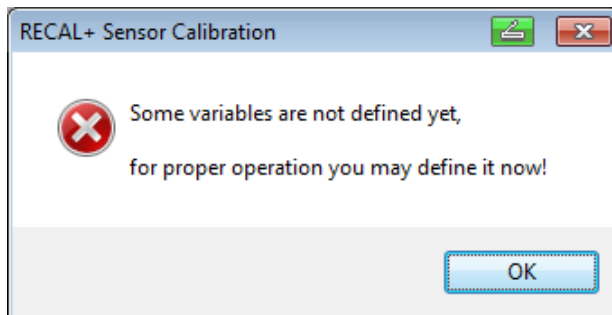

When **R&S® Recal+** is called for the first time, some variables are not yet defined. Accordingly, follow the prompt to enter the name and address of the calibration laboratory, initialize the measuring equipment, etc. The required steps are described in detail in the sections below. All entries are stored in the **re-cal32.ini** initialization file in the Windows directory and are applied automatically when **R&S® Recal+** is called again. They can be updated when necessary by using the **Options...** menu.

Entering the Name and Address of the Calibration Laboratory

The screenshot shows a dialog box titled "General Sensor Data". It is divided into two main sections: "Entries for storage in sensor EPROM" and "Entries for use with report printouts".

Entries for storage in sensor EPROM:

- Calibration Laboratory: R&S Service
- Person responsible: Patrick McNeal
- Company & Address: R&S International Service (with a character count of 25)
- Rohde-und-Schwarz-Str. 1
- 87700 Memmingen

Entries for use with report printouts:

- Calibration Date: 20150327 (2015-03-27)
- Software Version: 302 (3.02)

On the right side of the dialog, there are three buttons: "OK", "Cancel", and "Help".

- Enter the required information in the **General Sensor Data** dialog box:
 - Name of the calibration laboratory (max. 20 characters)
 - Name of the person carrying out the calibration: Up to 5 persons (max. 20 characters per entry). To enter a new name, mark the name currently displayed, overwrite it and complete the entry by pressing the Enter key. Use the **Delete** button to delete individual names
 - Name of the company to which the calibration laboratory belongs (max. 40 characters)
 - Company address (max. 40 characters)
- Press the **OK** button. For subsequent modifications, use the **General Sensor Data...** dialog box in the **Options** menu

Defining Directories

After correct installation, the subdirectories shown below should have been created. Confirm the settings by pressing the **OK** button or select other subdirectories by using the **Browse...** buttons.

Press the **OK** button. For subsequent modifications, use the **Directories...** dialog box in the **Options** menu.

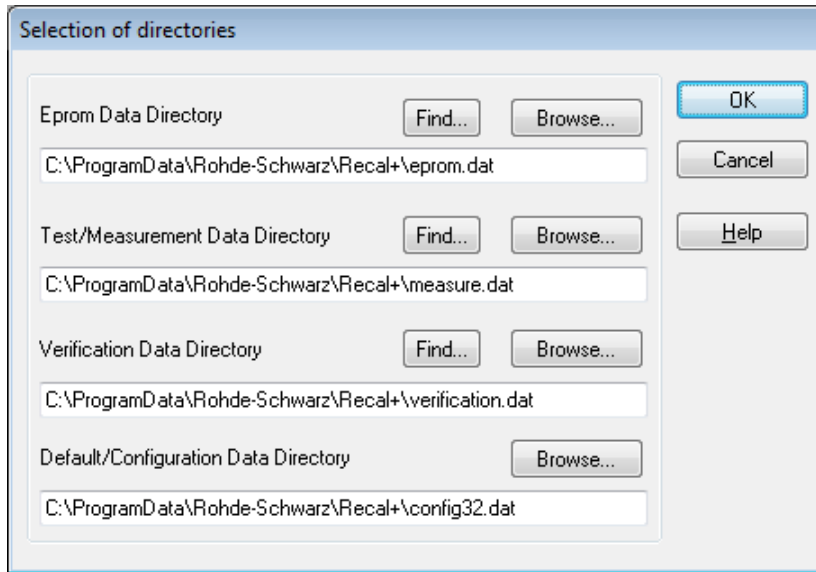

Update Additional Data for the R&S®NRVC Calibration Kit

The R&S®NRVC calibration kit requires additional data that is saved on the CD-ROM with the calibration data ⑨. After the *al...* and *af...* files have been copied from the CD-ROM, the message **To update additional data...** indicates that these files have to be activated explicitly by initializing the R&S®NRVD (see *Initializing the R&S®NRVD* in the next section).

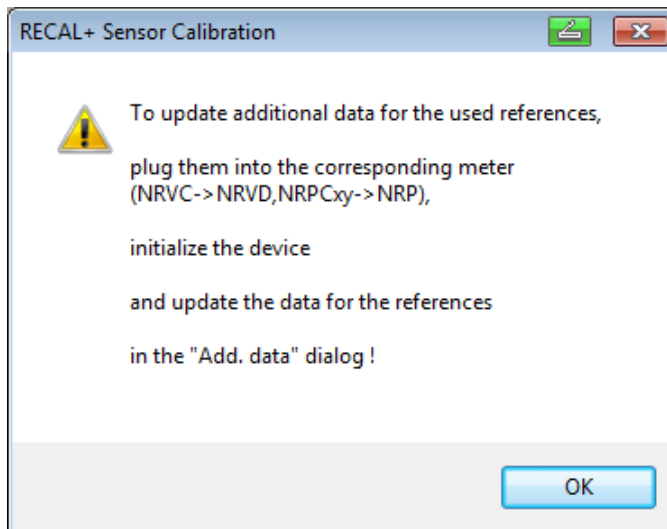

➤ Press the **OK** button to confirm the request

Initializing the Measuring Equipment

All remote-controlled measuring devices (the R&S®NRVD, R&S®NRP2, generator for calibration of absolute accuracy, generator for linearization and vector network analyzer) must be initialized before any measurements are made.

- Connect these devices via the IEC/IEEE bus to the controller and switch them on

Configuration of Power Meters with the R&S®NRPC Calibration Kit

Operating an R&S®NRPC calibration kit requires at least one R&S®NRP2 base unit to which the power standard and sensors in the R&S®NRP-Z and R&S®FSH-Z families can be connected. For calibration of sensors in the R&S®NRV-Z and R&S®URV5-Z series, an R&S®NRVD base unit is also necessary. Overall, two base units can be controlled: a basic power meter for connecting to the DUT and an R&S®NRP2 for connecting to one or up to four power standards from the R&S®NRPC calibration kits. The following tables show the possible combinations:

<i>Basic power meter</i>	<i>Meter2</i>
R&S®NRP2 A / B	R&S®NRP2 A / B / C / D
DUT (R&S®NRP-Z / R&S®FSH-Z)	Up to four R&S®NRPC ¹⁾

<i>Basic power meter</i>	<i>Meter2</i>
R&S®NRVD A / B	R&S®NRP2 A / B / C / D
DUT (R&S®NRV-Z / R&S®URV5-Z)	Up to four R&S®NRPC ¹⁾

¹⁾ The configuration of Meter2 depends on how many channels the R&S®NRP2 are fitted with.

<i>Basic power meter</i>	
R&S®NRP2	
A(B)	B(A)
R&S®NRPC	DUT (R&S®NRP-Z R&S®FSH-Z)

- Regardless of the selected combination, the R&S®NRPC reinitializes prior to calibration of a sensor. After pressing the **Add data ...** (Fig. 3-1) button, information is provided for each R&S®NRPC that was used in the last calibration. After changing the power standard, this information is not updated immediately. Instead, it is updated after launching a new measurement (button ).

Initializing the R&S®NRP2

- In the **Options** menu, open the **Remote Devices...** dialog
- Select the **Meter** tab
- Press the **Search NRP** button within the **Basic Power Meter** panel. The calibration software now searches for an R&S®NRP2 device from among the devices that are connected to the IEC/IEEE bus. If the search is successful, the address of the device is displayed in the address field. Press the **Search NRP** key again if a second R&S®NRP2 was found which should not be used as the **basic power meter**
- Press the **Initialize** button
- The calibration software initializes the R&S®NRP2 that was found at the specified address
- If a second R&S®NRP2 is available, press the **Use Meter 2** button and proceed accordingly

Note: *Meter2 is to be used exclusively to connect the standards during measurements!*

Configuration of Power Meters with the R&S® NRVC Calibration Kit

Operating an R&S® NRVC calibration kit requires at least one R&S® NRVD base unit to which the power standard, linearity standard and sensors from the R&S® NRV-Z and R&S® URV5-Z families can be connected. For calibration of sensors in the R&S® NRP-Z and R&S® FSH-Z series, an R&S® NRP2 power meter is also necessary. For calibration of sensors in the R&S® NRV-Z and R&S® URV5-Z series, it is recommended to connect a second R&S® NRVD base unit. A total of two base units can be used, i.e. a "basic power meter" for handling the DUT and a "Meter2" for handling the two standards. The following tables show the possible combinations:

Basic power meter	Meter2	
R&S® NRP2 A / B	R&S® NRVD A / B	
DUT (R&S® NRP-Z / R&S® FSH-Z)	R&S® NRVC (R&S® NRVC-B2)	R&S® NRVC-B2 (R&S® NRVC)

Basic power meter	Meter2	
R&S® NRVD A / B	R&S® NRVD A / B	
DUT (R&S® NRV-Z / R&S® URV5-Z)	R&S® NRVC (R&S® NRVC-B2)	R&S® NRVC-B2 (R&S® NRVC)

Basic power meter	
R&S® NRVD	
A(B)	B(A)
R&S® NRVC or R&S® NRVC-B2	DUT (R&S® NRV-Z R&S® URV5-Z)

➤ In the case of an initial installation or after a recalibration, always define the/an R&S® NRVD as the "basic power meter" in order to initialize the power standard and linearity standard (see following section)

Initializing the R&S® NRVD

- In the **Options** menu, open the **Remote Devices...** dialog box
- Select the **Meter** tab
- Press the **Search NRVD** button within the **Basic Power Meter** panel. The calibration software now searches for an R&S® NRVD device from among the devices that are connected to the IEC/IEEE bus. If the search is successful, the address of the device is displayed in the address field. If necessary, press the **Search NRVD** button again to find a second R&S® NRVD base unit. Note: If you already know the IEC/IEEE bus address of the required device, the search is not necessary and you can simply enter the address
- Press the **Initialize** button.
The calibration software initializes the R&S® NRVD that was found at the specified address
- In the case of an initial installation or after a recalibration, the power standard and the linearity standard are to be connected to the two measurement channels of this R&S® NRVD. The R&S® NRVD should then identify the two sensors and make the necessary entries in the **Channel A** and **Channel B** boxes (Fig. 3-1)
- Press the **Add data ...** button and enter the calibration expiry date and the **Certificate No.** for the addressed R&S® NRVD

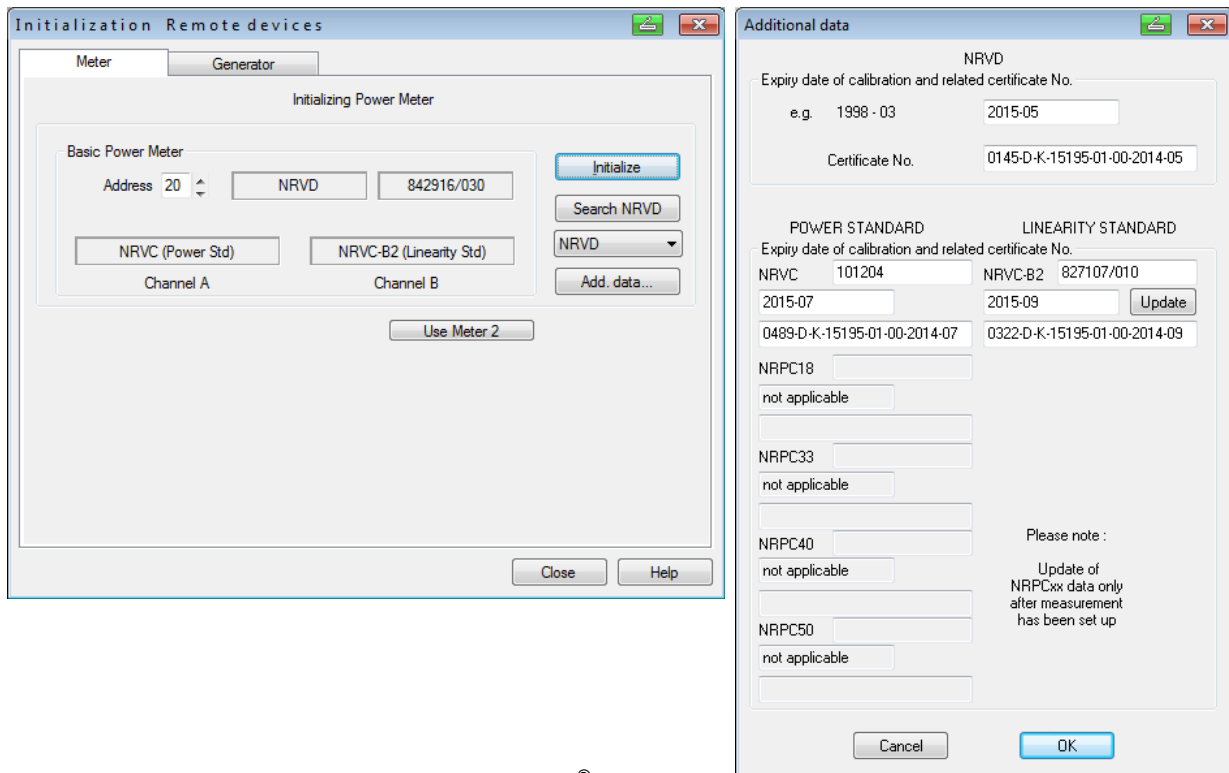

Fig. 3-1 Dialog boxes for initializing the R&S®NRVD and the two standards

- Press the two **Update** buttons (if available). The expiry date and the certificate number specified in the copied **af...** and **al...** files for the power standard and the linearity standard are then entered. Note: The **Update** buttons appear only if the data stored in the **af...** and **al...** files differs from that in the **re-cal.ini** file
- Press the **OK** button
- If a second R&S®NRVD is available, press the **Use Meter 2** button and proceed accordingly
- If an R&S®NRP2 base unit is connected to the measurement setup, select type NRP from within the **Basic Power Meter** panel and then press the **Search NRP** button first and then the **Initialize** button. Now, initialize the R&S®NRVD base unit connected to the setup as "Meter2"

Note: *Meter2 is to be used exclusively to connect the standards during measurements!*

Installing the remaining components of the R&S® NRVC or R&S® NRVC-B2

The reference attenuator, precision termination, power splitter ⑫ and harmonics filter ⑬ are also calibrated components of the R&S® NRVC calibration kit. In the calibration reports, they can be found under the section **Working Standards Used**. Thus, it is necessary to ensure that exactly the specified devices are used.

The corresponding calibration data is stored on the CD-ROM with calibration data in ASCII files under the following names:

- *at(NRVC.002)<xxxxxx>.<yyyy>* Reference attenuator
- *zz(NRVC.002)<xxxxxx>.<yyyy>* Precision termination
- *ap(NRVC.002)<xxxxxx>.<yyyy>* Power splitter
- *ah(NRVC.002)<xxxxxx>.<yyyy>* 50 MHz harmonics filter

To enable the **R&S[®]Recal+** calibration software to access these files, they were copied to the directory *...recalconfig32.dat* along with the other files (see section Defining Directories, page 40).

- Check the serial numbers of the components to be initialized to ensure that they match the file names: In the case of items with a new Rohde & Schwarz serial number, this number must be identical to *<xxxxxx>*. In this case, *<yyy>* is irrelevant. In the case of items with an old R&S[®] serial number, this number must be identical to *<xxxxxx.yyy>*
- If only one attenuator is to be used during operation, uncheck the "Confirm before each measurement" check box in the Attenuator dialog box. Otherwise, the software will prompt you for confirmation prior to each measurement that requires an attenuator. If more than one attenuator is to be used, the check box needs to remain selected to ensure that the appropriate file can be selected prior to each measurement

The dialogs can be examined at any time by opening them from the **Options** menu.

Initializing the Generators

- In the **Options** menu, open the **Remote Devices...** dialog box
- Select the **Generator** tab
- Select the type to be used in the **Generator (for absolute accuracy measurement)** panel
- Press the **Search Generator**, **Initialize** and **Add data...** buttons to initialize the generator and enter the calibration expiry date and the calibration certificate number. The serial number must also be entered in the case of some older generators. The procedure is the same as that for initializing the R&S®NRVD (see above)

Note: *If multiple generators for calibrating absolute accuracy are connected at the same time, e.g. an R&S®SMA100A-B106 and an R&S®SMF100A-B144, only one of the devices can be initialized. If the generator is replaced, reinitialization is necessary. The previously assigned IEC/IEEE bus address will automatically be suggested.*

In the **Generator (for linearity measurement)** panel, press the **Search Generator**, **Initialize** and **Add data...** buttons in that order and enter the calibration expiry date and the calibration certificate number (see above).

- Press the **Close** button. All **entries** are then stored in the **recal32.ini** file and can be automatically used by **R&S®Recal+** when the software is accessed again. For subsequent modifications, use the **Remote Devices...** dialog box in the **Options** menu

Initializing Network Analyzers

- In the **Options** menu, open the **Remote Devices...** dialog box
- Select the **Network Analyzer** tab
- Select the type that is used
- Press the **Search Analyzer**, **Initialize** and **Add data...** buttons to initialize the vector network analyzer and enter the calibration expiry date and the calibration certificate number. The procedure is the same as that for initializing the R&S®NRVD (see above)
- Press the **Close** button. All **entries** are then stored in the **recal32.ini** file and can be automatically used by **R&S®Recal+** when the software is accessed again. For subsequent modifications, use the **Remote Devices...** dialog box in the **Options** menu

Note: *In order for the **Network Analyzer** tab to appear, the additional program ZVX_RECAL must be installed.*

Performing the Calibration

A power or voltage sensor is calibrated in several phases that are shown in Table 3-1 in the appropriate order. After the incoming inspection, calibration of the incoming condition is performed for the matching, absolute accuracy and linearity. The software checks the resulting data for compliance with the appropriate tolerance limits. For sensors whose correction factor set can be refreshed, this data forms the basis for a new correction factor set.

As the next step, an initial report can be generated with the **Calibration Report (Incoming)**. This documentation should be prepared as a rule for all sensors whose correction factor set (EPROM file) cannot be overwritten, e.g. for all voltage sensors in the R&S®URV5-Z series. For these sensors, the calibration process is also generally complete once the **Calibration Report (Incoming)** is generated. DUTs that exceed the tolerance limits must be sent to the manufacturer for repair.

In the case of sensors whose correction factor set can be overwritten (i.e. almost all of the power sensors), reporting of the incoming condition is necessary only if the DUT exhibited non-compliance with the relevant specifications. If the measurement errors are so large that the device is clearly damaged or subject to unnatural premature ageing, the DUT must also be sent for repair. Otherwise, the correction factor set may be overwritten.

The new correction factor set is obtained from the measurement results gathered during the incoming test and the saved correction factors. Overwriting the data memory with this data ensures that the DUT uncertainty during subsequent usage is only slightly larger than the uncertainty of the calibration. In order to verify this, the absolute accuracy is generally tested once again after the data memory is refreshed. For some sensors, this also includes a check of the linearity (with the modified correction factors). The measurement results are documented with the **Calibration Report**. Archival of all relevant data represents the completion of the calibration cycle.

The sequence of calibration steps suggested in Table 3-1 is not mandatory when using the **R&S®Recal+** calibration software, i.e. users are free to create a calibration cycle that best meets their requirements. For example, they can choose to omit documentation, repeat measurements several times or omit individual calibration steps (e.g. linearization or matching). On the other hand, it is not possible to select meaningless combinations such as calculating a new EPROM file without measurement data. The following sections explain each of the calibration steps in detail.

Table 3-1 Overview of a complete calibration cycle

Phase		Section	Comments
I	Preparation	Incoming inspection	
II	Calibration on delivery	Checking matching	
		Checking linearity	
		Checking absolute accuracy	
		Measuring the attenuator, if relevant	On ext. meas. setup (only for the R&S®NRP-Z22/23/24/92)
III	Documentation of calibration	Generating the calibration report (incoming)	
IV	Refreshing the data memory	Calculating a new EPROM file Overwriting the data memory	Only sensors whose correction factor set can be overwritten
V	Outgoing calibration	Checking absolute accuracy [Checking linearity]	
VI	Documentation of calibration	Generating the calibration report	
VII	Archiving	Archiving	

- Important:**
- *The ambient temperature during calibration should be 23 °C. Deviations of (-3/+2) °C maximum are permissible, but should be avoided if possible. Larger temperature deviations may cause the measurement uncertainties specified for the R&S®NRVC and R&S®NRPC calibration kits to be exceeded*
 - *Allow the test setup to warm up for at least one hour prior to calibration*
 - *After the power standard and linearity standard are connected to the base unit, allow them to warm up for at least one hour*
 - *Sensors in the R&S®URV5-Z and R&S®NRV series must be allowed a few minutes to obtain normal operating temperature after insertion into the R&S®NRVD base unit. Due to their higher self-warming, power sensors in the R&S®NRP-Z and R&S®FSH-Z series require about 30 minutes to warm up on an R&S®NRP2 base unit or PC*

Incoming Inspection

To prevent measurement errors during calibration as a result of soiled, worn or loose RF connectors and cabling that has sustained wear and tear, the DUT should be examined closely by performing a few simple inspections and tests before the main measurements are performed. This also prevents any potential damage to the calibration kit:

- Inspect the sensor cable for external damage and verify that it is properly connected to the sensor and data memory
- Clean the RF connectors
- Check the position of the inner conductor with respect to the reference plane of the RF connector
- Connect the DUT to a suitable base unit
- Connect the DUT's RF interface to the test generator and make sure there is a good connection between the connector and the sensor casing
- Power on the test generator. The power reading must be stable even if the sensor cable is moved or the sensor casing is bent or twisted slightly

Only for sensors in the R&S®NRP-Z or R&S®FSH-Z series:

- Launch the **R&S®Recal+** software and initialize the base unit as a **basic power meter**
- Press the  button in the toolbar and open the **NRP Sensor Test** tab
- Select the DUT and perform the built-in self-test by pressing the **Execute Test** button. The test results consist of a global "SUCCESSFUL / FAILED" assessment along with individual test results

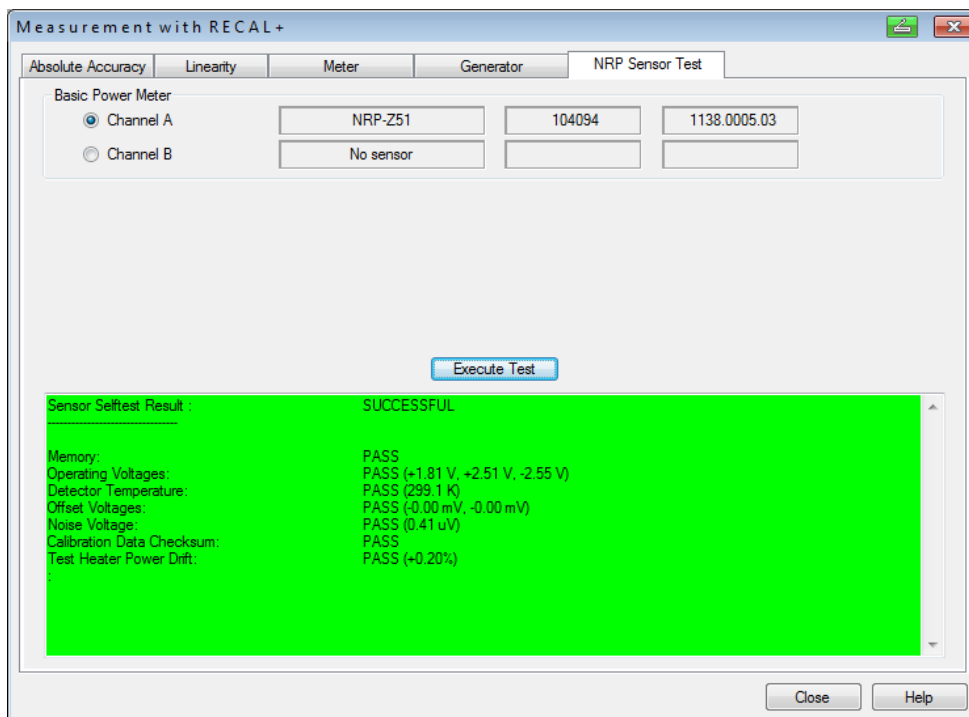

Fig. 3-2 NRP Sensor Test tab with measurement results

Checking the Matching

The DUT's matching is measured with the aid of a vector network analyzer. The required steps are described under *Measurements on a Separate Measurement Setup* in the *Matching* section of the appendix.

If it is necessary to measure the absolute accuracy with gamma correction, the DUT's reflection data must be determined beforehand and saved in the directory ...*recal\measure.dat* . Otherwise, the gamma correction function cannot be activated.

Checking the Linearity

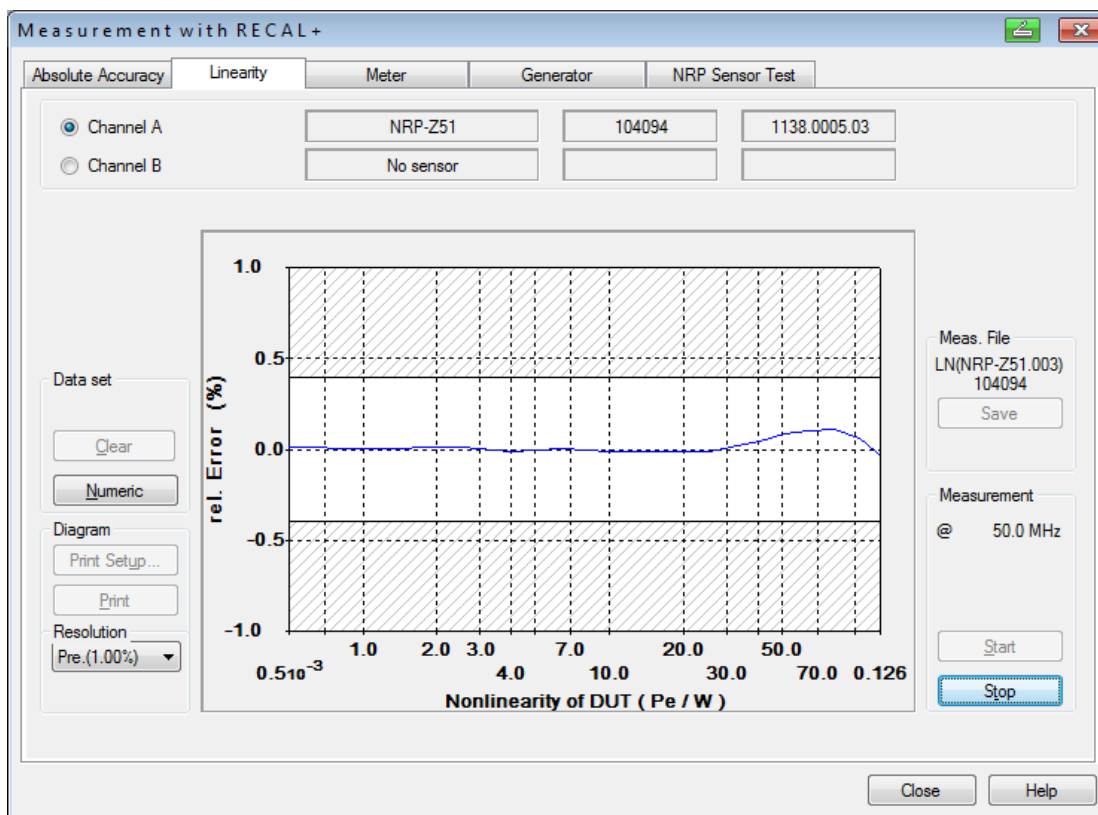



Fig. 3-3 Linearity tab at the end of a measurement procedure

- Prepare the appropriate test setup for the sensor as described in Fig. 2-22 to Fig. 2-28
- Initialize any measuring devices that have not yet been initialized (**Meter** or **Generator** tab)
- Press the  button in the toolbar
- Select the **Linearity** tab
- Select the graphics or numerical display mode for measured values (see below for explanation)
- Press the **Start** button:

The linearity measurement will now start. Starting from the sensor's specific reference power, the power applied to the DUT is increased until the nominal power is reached. The relative changes in power measured by the DUT (voltage changes for the R&S®URV5-Z... sensors) are compared with the changes measured by the linearity standard and output as linearity errors in %.

Note: During the linearity measurement on R&S®NRP sensors, the R&S®NRP2 base unit may generate an overload message at the last level step. It is safe to ignore this message.

- Check whether the measured errors are within the tolerance band in the graphical display
- Press the **Save** button to save the measurement results in a file with the specified file name

Note: Only saved measurement results can be output in the calibration report and taken into account when the data memory contents are recalculated.

Repeating incorrect measurements

Occasionally, a measurement may have to be repeated because, for example, the sensor's RF connector is loose. In this case, press the **Start** button to restart the measurement.

Displaying the measurement results on screen

The linearity errors of the DUT can be displayed in graphical or list format. You can toggle between the two modes by pressing the **Numeric (Diagram)** button. Graphical displays can be printed out by pressing the **Print** button.

Graphical display (nonlinearity of DUT)

The linearity errors of the DUT are plotted as the **Rel. error (%)** together with the tolerance band versus the input power P_{in} or the input voltage V_{in} . Generally, it can be assumed that a sensor that exceeds the tolerance limits is defective and must be sent back to Rohde & Schwarz central service for repair. This applies at least to all sensors for which a correction of the linearity is not possible (see Table 1-4 to Table 1-7). The measurement points at which the tolerance limits are exceeded are indicated by an asterisk (*) in the calibration report.

The vertical resolution of the diagram can be set to a customized scaling or via the **Resolution** control panel using one of the following four settings: **Pre. (x %)** / **Fine (1 %)** / **Coarse (50 %)** / **y %**. **Pre. (x %)** yields the optimum resolution for the sensor (Preset) and **y %** is the customized scaling last selected. Customized scaling can be set as follows:

- Move the mouse cursor to the label for the highest value on the scale and wait for the  symbol to appear. Then double-click and enter the number needed for this maximum value

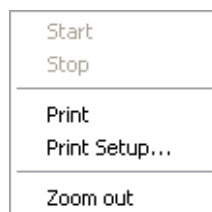

To enlarge the graphical display, position the mouse cursor over the diagram, wait for the  symbol to appear and double-click. By clicking the right mouse button, you can display a contextual menu (figure on left) in the zoomed mode without having to return to the normal display (Esc key).

Outputting numeric measured values

The list has four columns, namely the index number of the level step (**Index**), the nominal level step (**Nom. Level** in **W** or **V**), the value measured for the DUT (**Meas. Level** in **W** or **V**) and the linearity error of the DUT (**Error** in %).

Troubleshooting measurement problems

Problem	Cause / ⇒ Solution
<ul style="list-style-type: none"> • The Start button cannot be pressed 	<p>The linearity standard and/or DUT are not connected to the R&S®NRVD or R&S®NRP2:</p> <ul style="list-style-type: none"> ➤ Check the test setup as shown in Fig. 2-22 to Fig. 2-28 <p>The R&S®NRVD, R&S®NRP2 and/or generator have not been initialized:</p> <ul style="list-style-type: none"> ➤ Select the Meter and/or Generator tab and repeat the initialization
<ul style="list-style-type: none"> • The following error message appears at the start of or during the measurements: Error detected: Measurement out of tolerance (+/- 50%) Please check your test equipment 	<p>The level on the linearity standard and/or DUT is too high/low:</p> <ul style="list-style-type: none"> ➤ Check the test setup as shown in Fig. 2-22 to Fig. 2-28 ➤ Verify the calibration kit

Checking the Absolute Accuracy

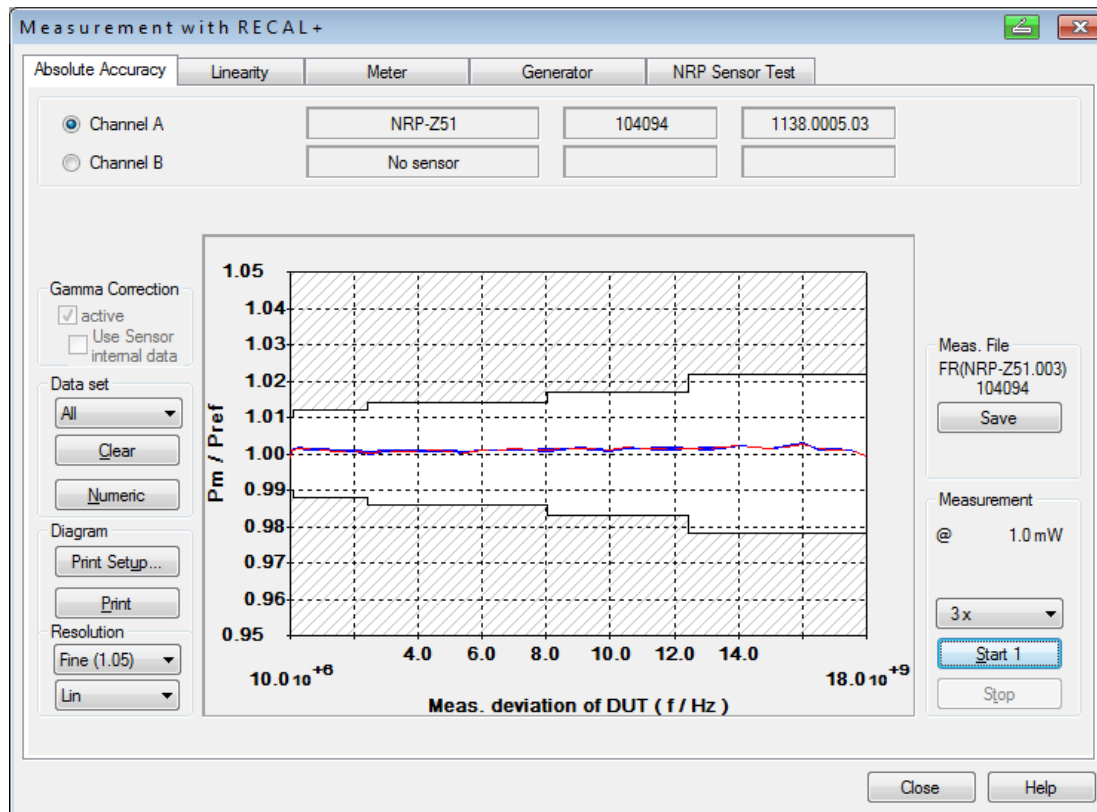



Fig. 3-4 Absolute Accuracy tab at the end of a measurement sequence.

- If the measurement is to be performed with gamma correction, determine the DUT's reflection data beforehand and save the data in the `...\\recal\\measure.dat` directory
- Prepare the test setup as shown in Fig. 2-6 to Fig. 2-21
- Initialize the measuring devices that have not already been initialized (Meter and Generator tabs)
- Press the  button
- Select the **Absolute Accuracy** tab
- Select the measurement channel to which the DUT is connected
- If the measurement must be performed with gamma correction for the sake of accuracy (generally for all thermal sensors in the R&S[®]NRP-Z series and all sensors with a frequency range of more than 18 GHz), the corresponding check box must be activated. The measurement can then be started only if reflection data is available for the DUT in complex notation. Otherwise, an error message will appear! In order to still perform a measurement, the check box for gamma correction must be deactivated by the user. In this case, the software outputs a warning after the measurement is started. The measurement data generated in this manner may not be used to create a new correction factor set

If gamma correction is not required for the DUT, the check box is deactivated immediately after opening the dialog. However, it can be activated to increase the accuracy, but the reflection data for the DUT must then be available in complex notation.

For the sensors in the R&S[®]URV5-Z series, gamma correction is not possible in any case.

- Specify the number of measurement cycles in the control panel on the far right (1x, 2x, 3x, 4x). For the incoming calibration, at least three cycles should be performed as a basis for recalculating the correction factors. For the second calibration after the data memory has been overwritten, one measurement is usually sufficient because the measurement errors are very small
- Select graphical or numeric result display (see explanation below)
- Press the **Start 1** button:

The first cycle is started. When measurements are performed with the reference attenuator, the **Attenuator** dialog box may appear shortly after the start. Press the **OK** button only if you are sure that the displayed file is the correct one for the attenuator in the measurement setup (file name to the right of the **at** header is identical to the serial number of the attenuator).

Otherwise, select the appropriate file from the **file selection** list. The routine display of the **Attenuator** dialog box can be suppressed by clearing the **Confirm before each measurement** check box.

If several measurement cycles are carried out, the following dialog box is displayed after each cycle:

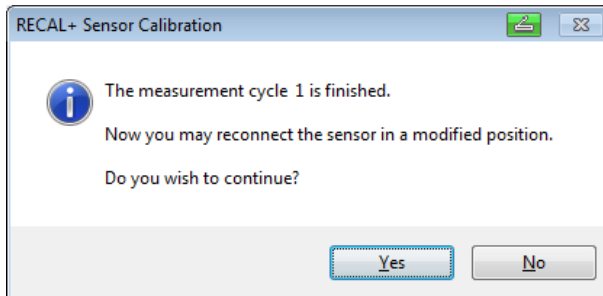

- Undo the RF connector and turn the sensor/attenuator by 90°, 120° or 180° (Fig. 3-5) depending on the number of cycles. Treat the power attenuator of the R&S®NRV-Z32/-Z33/-Z53/-Z54 sensors as the reference attenuator. Then press the **Ja** (Yes) button. Once the measurement sequence has been completed, the averaged power or voltage ratio is displayed as a red line in the diagram
- Press the **Save** button to save the measurement results in a file with the specified file name

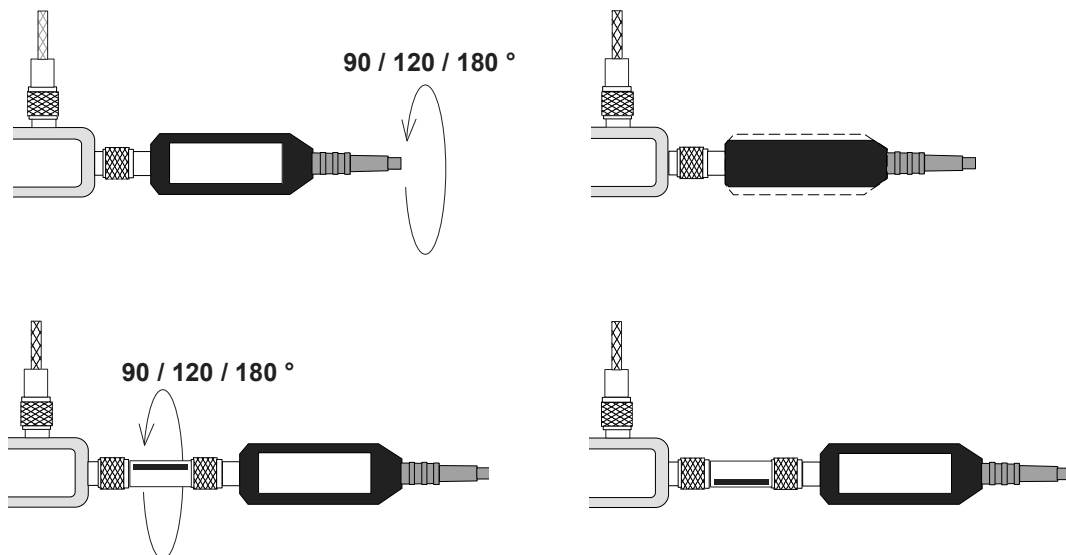

Fig. 3-5 Turning the sensor or attenuator before the next measurement cycle.

Note: Only saved measurement results can be output in the calibration report and taken into account when the data memory contents are recalculated.

Repeating faulty measurements

Occasionally, a measurement may have to be repeated because, for example, the sensor's RF connector is loose. In this case, mark the faulty cycle in the **Data set** control panel and press the **Clear** button. The associated measurement result display is then removed from the diagram. Then press the **Start...** button to repeat the measurement.

Displaying the measurement results on screen

The measurement errors of the DUT can be displayed in graphical or list format. You can toggle between the two modes by pressing the **Numeric (Diagram)** button. Graphical displays can be printed out by pressing the **Print** button. The data to be displayed can be selected via the "Data Set/Path" control panel (in the case of the R&S[®]NRP-Z sensors) or "Data Set" (in all other cases).

Graphical display (Meas. deviation of DUT)

The measurement errors of the DUT are displayed together with the tolerance band as a power ratio P_m/P_{ref} or a voltage ratio V_m/V_{ref} (index m: DUT) versus frequency. The R&S[®]URV5-Z2/-Z4/-Z7 and R&S[®]NRV-Z31/-Z32/-Z33 sensors should be considered defective if the tolerance limits are exceeded, in which case they must be sent back to Rohde & Schwarz central service for repair. Otherwise, a decision must be made on a case-by-case basis. Out-of-tolerance conditions below 1 GHz often indicate that the sensor is defective. The measurement points at which the tolerance limits are exceeded are indicated by an asterisk (*) in the calibration report.

Graphical display can be set via the **Lin/Log** (scale for frequency axis) and **Resolution** (vertical resolution) control panels. Vertical resolution can be customized, or one of the following four settings can be selected - **Pre. (x)** / **Fine (1.05)** / **Coarse (1.5)** / **y**. The **Pre. (x)** setting yields the optimum resolution (Preset) for the sensor and **y** is the customized scaling last selected.

Customized scaling can be set as follows:

- Move the mouse cursor to the label for the highest value on the scale and wait for the $\{m\}$ symbol to appear. Then double-click and enter the number needed for this maximum value



To enlarge the graphical display, position the mouse cursor over the diagram, wait for the $\{m\}$ symbol to appear and double-click. By clicking the right mouse button, you can display a contextual menu (figure on left) in the zoomed mode without having to return to the normal display (Esc key).

Outputting numeric measured values

The list has four columns, namely the index number (**Index**) of the frequency point, the frequency (**Frequency**), the power ratio P_m/P_{ref} or the voltage ratio V_m/V_{ref} (**Factor**) and the measured value for the power standard (**Level**). The values that are output are for the current measurement.

Usage of torque wrenches

All of the R&S[®]NRPC calibration kits include an appropriate torque wrench for the given connector type. The torque is set to ensure a dependable connection and also to prevent wear and tear. Experience has shown that trained personnel can obtain the same reproducibility that is possible with the torque wrench even without using this tool.

In the case of the newer thermal sensors in the R&S[®]NRP-Z5x series which are equipped with a very free-moving nut with ball bearing mounting, the torque wrench is definitely unnecessary. In fact, it can even be counterproductive due to the looseness of the nut since the connection is always tightened somewhat too tight.

Troubleshooting measurement problems

Problem	Cause / ⇒ Solution
<ul style="list-style-type: none"> The Start... button cannot be pressed 	<p>The linearity standard and/or DUT are not connected to the R&S®NRVD or R&S®NRP2:</p> <ul style="list-style-type: none"> ➤ Check the test setup as shown in Fig. 2-6 to Fig. 2-21 <p>The R&S®NRVD, R&S®NRP2 and/or generator have not been initialized:</p> <ul style="list-style-type: none"> ➤ Select the NRVD and/or Generator tab and repeat the initialization
<ul style="list-style-type: none"> The following error message appears at the start of or during the measurements: Error detected: Measurement out of tolerance (± 50%) Please check your test equipment 	<p>The level on the linearity standard and/or DUT is too high/low:</p> <ul style="list-style-type: none"> ➤ You forgot to insert or remove the reference attenuator, or the power standard is not connected to the generator ➤ Check the test setup as shown in Fig. 2-6 to Fig. 2-21 ➤ Verify the calibration kit
<ul style="list-style-type: none"> The measurement result spread for the cycles is too large 	<p>The DUT, power standard or attenuator is defective:</p> <ul style="list-style-type: none"> ➤ Verify the calibration kit

Generating the Calibration Report

A calibration report documenting the calibration procedure can be generated at any time. It contains a cover sheet with general information, a list of the measuring equipment used, and a list of the measurement results. There are two versions of the calibration report:

The **Calibration Report (Incoming)** documents the incoming condition, and the **Calibration Report** describes the status after the data memory has been overwritten and the final control measurements have been performed. While the **Calibration Report (Incoming)** is merely a straightforward measurement report listing all measurement points, the **Calibration Report** additionally contains information about the stored calibration factors. Since only measurement points for which correction factors are stored are listed, the report should be generated only when the data memory is overwritten. Depending on the sensor type, proceed as follows (see Table 1-4 to Table 1-7):

DUTs without refreshing the data set

Only the **Calibration Report (Incoming)** is output since the data memory contents were not overwritten.

DUTs with refreshing of the data set:

The **Calibration Report** is always output on completion of the control measurements in order to provide proof of calibration. If the tolerance limits were exceeded on incoming inspection, the **Calibration Report (Incoming)** should also be output.

The calibration reports are generated as follows:

- Open the **Calibration reports...** dialog in the **Calibration** or **File** menu.
The **Report Generation** dialog box opens
- Mark the measurement channel to which the calibrated sensor is connected or select the EPROM file for the sensor from the file list that is displayed (file name: **ep(<sensor><serial no.>**)
- Select **Calibration Report (Incoming)** or **Calibration Report**
- For complete documentation, fill out the **Report No.** and **Customer** boxes
- Press the **OK** button: The calibration report, excluding the cover sheet and the list of measuring equipment, is displayed on screen

- To view the complete calibration report on the screen, select the **Print Preview...** dialog in the **File** menu
- Print out the calibration report

If you wish to store electronic copies of calibration reports, install a printer driver for creating Acrobat PDF files. These drivers are available from various third-party suppliers.

Note regarding the Calibration Report (Incoming) for R&S® NRP-Z and R&S® NRV-Z sensors:

As soon as the new EPROM file for the sensor has been calculated (described later in this chapter), the R&S® Recal+ software stores a backup copy of the incoming calibration and the data memory contents in the ...\\recal\\measure.dat\\income and ...\\recal\\eprom.dat\\income subdirectories. This allows the **Calibration Report (Incoming)** to be output at the very end of calibration. R&S® Recal+ accesses the saved files and will use the data from the ...\\recal\\measure.dat or ...\\recal\\eprom.dat directory for the **Calibration Report (Incoming)** only if it does not find data for the sensor in the "income" subdirectories.

To avoid incorrect calibration reports when the entire procedure is repeated, all files with the serial number of the sensor must be deleted from the "income" subdirectories prior to the first measurement (see also the **Archival** section).

Suppressing the Rohde & Schwarz logo

The ROHDE & SCHWARZ logo in the upper right-hand corner of the calibration report can be suppressed as follows: Using a text editor, open the **recal.ini** file in the Windows directory, go to the

[LAB ID]

section and make the following entry:

NoLogo = TRUE



ROHDE & SCHWARZ

Calculating a New EPROM File

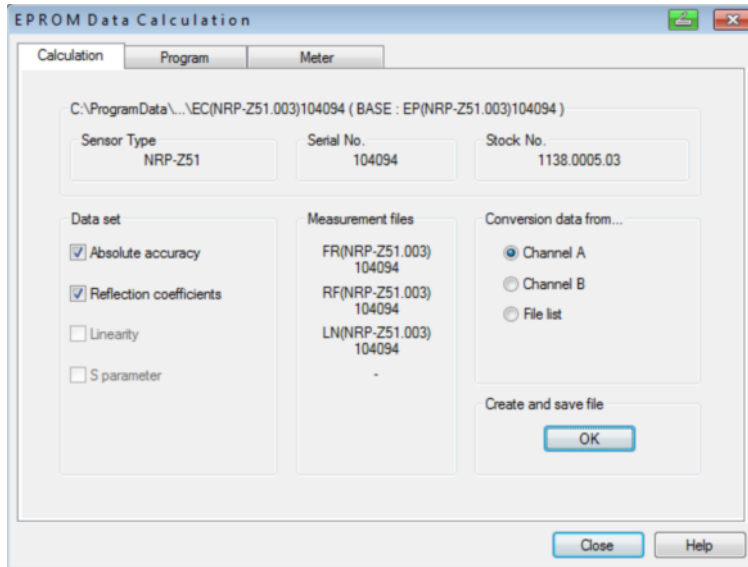

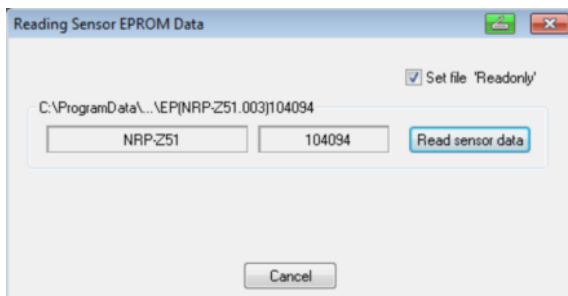

Fig. 3-6 Calculation tab with measurement files present

The following section only applies to sensors whose data memories are to be overwritten. This involves generating a new EPROM file from the measurement results and the sensor's (old) EPROM data, which can be loaded into the sensor via the R&S[®] NRVD or R&S[®] NRP2 or, in the case of sensors with UV-erasable EPROM, by means of a suitable programming device (see following section). The calculation is performed as follows:

- Press the  button
- Select the **Calculation** tab
- Specify the source of the (old) EPROM file:
 - Either mark the measurement channel to which the sensor in question is connected, or select the **File List** radio button and select the appropriate EPROM file **ep(<sensor><serial no.>** from the list
 - If the EPROM file is selected via the measurement channel, a prompt to read in sensor data will appear in most cases. Press the **Read sensor data** button, wait for the end of the read operation and close the dialog box by pressing the **Cancel** button



- If measurement data is available for the selected EPROM file, this is indicated in the **Data set** field on the **EPROM Data Calculation** tab; the file names are listed in the **Measurement files** field
- Click the **Create and save file** button: The R&S[®] Recal+ software then calculates a new EPROM file and saves it under the name **ec(<sensor><serial no.>**. When finished, the message **...is saved** is output

Overwriting the Data Memory of a Sensor with Flash EPROM

Any compatible file can be written to a sensor data memory. The file would normally be a new file named **ec(<sensor><serial no.>** that is generated from measurement data. However, after the data memory has been overwritten, it is also possible to restore the original contents from file **eo(<sensor><serial no.>**.

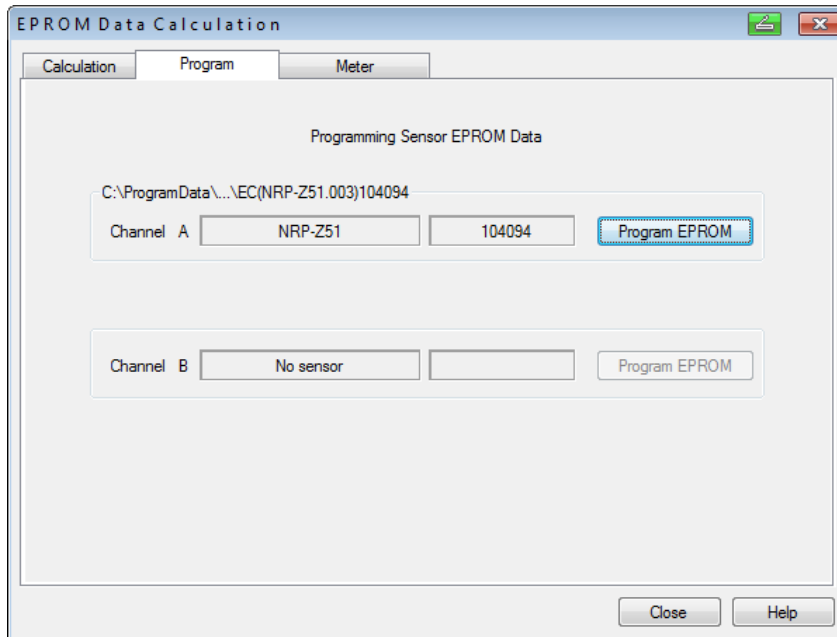

- Connect the sensor to channel A or channel B on the R&S®NRVD or R&S®NRP2 (if not already done)
- Press the  button (if not already done)
- Select the **Program** tab
- Depending on the button label (at right), various options are available for the measurement channel in question:
 - If the button label is **Program EPROM**:
A recalculated EPROM file **ec...** whose name contains the serial number of the sensor is available. To overwrite the data memory with this file, press the **Program EPROM** button and confirm the operation again.
If a different file is to be used to overwrite the data memory, first delete file **ec...** whose name contains the serial number of the sensor from the **...recal/eprom.dat** directory (with the file manager or Explorer) and continue to the next step:
 - If the button label is **Browse**:
No EPROM file **ec...** whose name contains the serial number of the sensor is available. Instead, any file can be selected from the **...recal/eprom.dat** directory by marking the file, pressing the **Program EPROM** button and then confirming the operation again
 - If the button label is **Read only**: It is not possible to write data to the data memory via the R&S®NRVD (UV-EPROM, see following section)
- After the flash EPROM has been erased and overwritten (this may take a few minutes depending on the amount of correction data), press the **Close** button

Archiving

To prevent conflicts between old and new data, the files generated during calibration must be deleted from the *...\\recal\\eprom.dat* and *...\\recal\\measure.dat* working directories and the *...\\income* subdirectories at some point before the individual sensor is calibrated again.

R&S® Recal+ provides an archiving function allowing files to be copied to a new directory, deleted from the working directories and dearchived.

Copying Files to Archive

- Using Windows Explorer or the file manager, create an archive directory, e.g. ...**recal**\archive
- Launch **R&S®Recal+** and select the **Archive...** dialog in the **File** menu
- The **Archiving/Cleaning of NRVC Working Directories** dialog box is opened

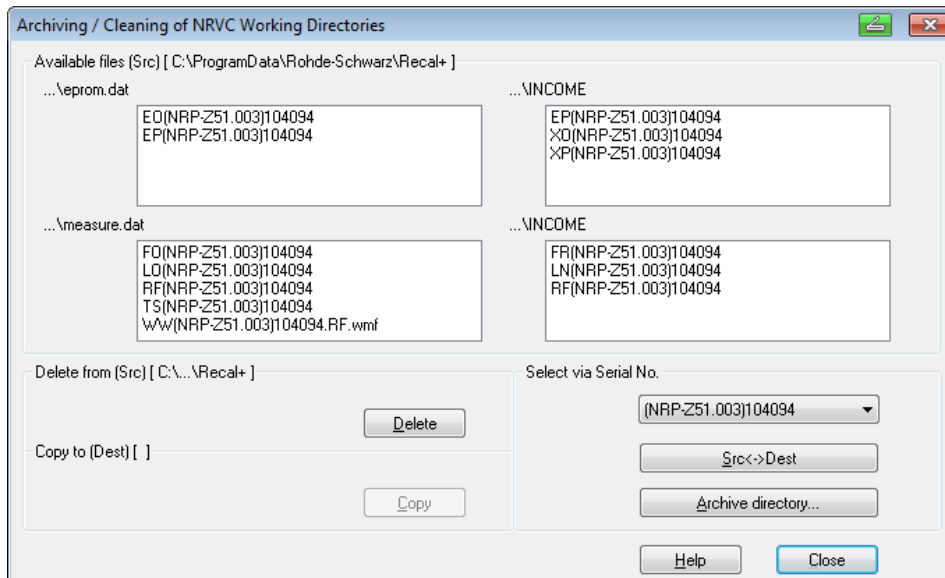

- In the **Select via Serial No.** panel, select the sensor to be archived
- All files available in the working directories are displayed
- Select the archive directory via the **Archive directory** button
- Press the **Copy** button
- **R&S®Recal+** copies all files to the archive directory. Subdirectories **...\eprom.dat**, **...\measure.dat** and **...\income** are created automatically
- Press the **Delete** button to delete the files from the working directories

Note: *If only some of the files are to be copied or deleted, first select them with a mouse click.*

Fetching Files from Archive

This procedure is identical to that for archiving except that the source and target have to be interchanged via the **Src<->Dest** button. The archive directory should then be displayed under **Delete from (Src) [...]** and the working directory under **Copy to (Dest) [...]**. You can switch back to archiving by pressing the **Src <-> Dest** button again.

4 Verification

In order to prevent faulty calibration of sensors, it is necessary to check the measurement accuracy of the power standards using the verification set (option B1). Like a normal calibration of absolute accuracy, verification with the verification set is a quick and easy process that should be performed on a regular basis (prior to usage or daily).

Verification of the R&S® NRPC Calibration Kit

Built-In Self-Test of the Power Standard

The R&S® NRPC ① power standards are equipped with an internal reference circuit for checking the long-term stability of the integrated power sensor. The reference circuit includes a highly stable DC voltage source which can be used to supply a second heater on the transducer. The reference circuit is activated whenever a built-in self-test is performed and an in-circuit test is executed. Proceed as follows to perform the self-test:

- Press the  button in the toolbar and open the **NRP Sensor Test** tab
- Select the power standard and perform the built-in self-test by pressing the **Execute Test** button

The test results consist of a global "SUCCESSFUL / FAILED" assessment along with individual test results. The result of the in-circuit test is displayed under the *Test Heater Power Drift* item. Along with a "SUCCESSFUL / FAILED" assessment, the percent is indicated by which the sensitivity of the test cell has changed compared to the last calibration by German Accreditation Body (DKD) laboratory D-K-15195-01-00.

The R&S® NRPC-B1 verification kit should also be subjected to a built-in self-test in the same manner. Here too, the change in the measured sensitivity compared to the last calibration by the German Accreditation Body laboratory mentioned above is displayed under the *Test Heater Power Drift* item.

In-circuit testing of the power standard can be triggered as part of a user-initiated self-test and is also executed automatically by the **R&S® Recal+** software prior to each calibration of absolute accuracy.

Comparison Measurements with the R&S® NRPC-B1 Verification Set

For each R&S® NRPC calibration kit, an R&S® NRPC-B1 verification kit ②④ can also be ordered as an option. It consists of a thermal sensor with an input impedance of 100 Ω. These R&S® NRPC18-B1, R&S® NRPC33-B1, R&S® NRPC40-B1 and R&S® NRPC50-B1 thermal sensors have been adjusted on the associated power standard and exhibit only very minor errors compared to it. Therefore, large errors indicate that there has probably been some change in the components involved. Due to the strong mismatch of the verification sensor, it is possible to detect aging or wear and tear at an early stage in terms of the power measurement accuracy as well as the matching. Usage is very simple:

- Verify that the calibration kit matches the verification kit by comparing the serial numbers of the power standard with the data on the bottom of the verification sensor
- Prepare the measurement setup for checking the absolute accuracy as shown in Fig. 2-6 for the R&S® NRPC33, Fig. 2-15 for the R&S® NRPC33, Fig. 2-18 for the R&S® NRPC40 and Fig. 2-21 for the R&S® NRPC50
- Check the absolute accuracy with the associated verification kit

Perform one or more measurement cycles (depending on requirement); otherwise proceed as described under **Checking the Absolute Accuracy**. The averaged trace must lie within the tolerance band shown in the graphical display. The tolerance limits are significantly tighter compared to a normal thermal sensor. If the trace rises or falls uniformly over all of the frequency range, this indicates a change in the sensitivity of the power standard or the verification sensor. An oscillating frequency response as seen in Fig. 4-1 indicates that the matching conditions on the RF connection have changed. In this case, a visual inspection is necessary and the connectors should be cleaned. If the ripple does not disappear despite cleaning the connectors of the verification sensor and the power standard, the RF connector for the power standard can be exchanged with the supplied replacement adapter ⁽²¹⁾. For a description of the steps required to do this, see the appendix under **Exchanging the RF Connector at the Test Port of the Power Standard**.

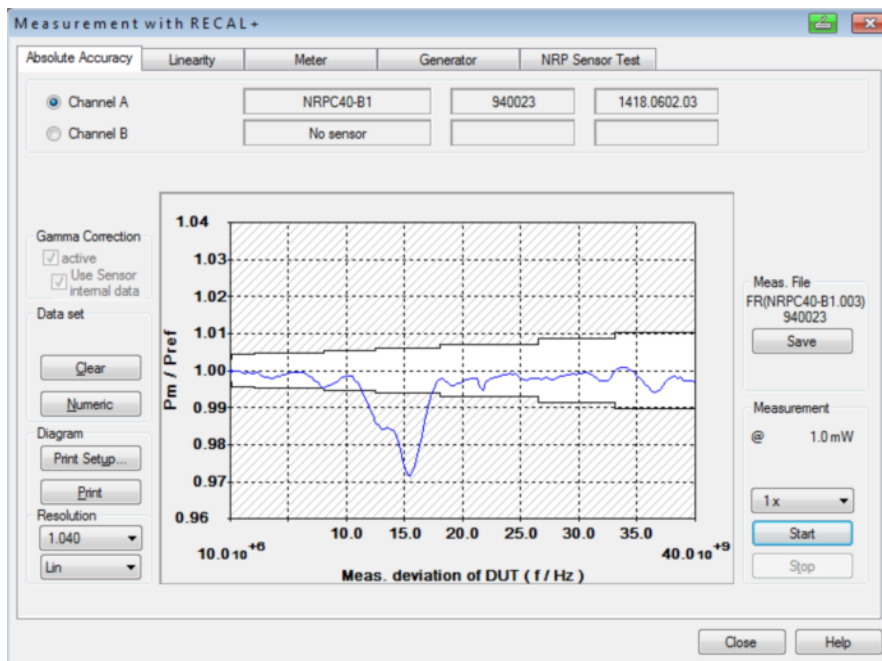

Fig. 4-1 Verification result for an R&S[®]NRPC40 power standard following damage to the RF connectors

The reference attenuators ⁽²⁾ in the R&S[®]NRPC18, R&S[®]NRPC33 and R&S[®]NRPC40 are not checked.

Note: The verification measurement with the R&S[®]NRPC-B1 is saved as an FR file with a time stamp in the Verification.dat folder.

Verification of the R&S®NRVC Calibration Kit

To ensure the measurement accuracy of the R&S®NRVC calibration kit, all key components – i.e. power standard, linearity standard and reference attenuator – need to be checked regularly. There are two ways of doing this:

- Perform comparison measurements using the two sensors from the R&S®NRVC-B1 verification set
- Check the measurement accuracy using a DC voltage

The comparison measurements with the verification set can be performed via a software program in just a few minutes and are, therefore, the obvious choice for daily functional checks. DC voltage measurements should be performed less frequently, e.g. once a month, in order to check the stability of the power standard, the reference attenuator and the thermal sensor from the verification set. Any errors that are detected can be corrected to compensate for drift resulting from aging or ambient conditions.

An initial verification – including the **DC voltage tests** – should be performed immediately after the calibration kit is put into operation the first time.

Comparison Measurements with the R&S®NRVC-B1 Verification Set

The R&S®NRVC-B1 verification set contains two sensors: an R&S®NRV-Z1 diode power sensor and an R&S®NRV-Z51 thermal power sensor. Both have been adjusted on the individual calibration kit and exhibit minimum measurement errors with respect to this kit. Large errors indicate that there has probably been some change in the components involved. The verification set can thus detect aging or wear and tear at an early stage, but it cannot be used to recalibrate the measuring equipment.

Use is straightforward:

- Verify that the calibration kit matches the verification kit by comparing the serial numbers of the power standard, reference attenuator and linearity standard with the data on the bottom of the two verification sensors.
- Prepare the measurement setup for checking the absolute accuracy as shown in Fig. 2-8 for an R&S®NRV-Z51 sensor.
- Check the absolute accuracy with the R&S®NRV-Z51 sensor from the verification set. Perform one or more measurement cycles (depending on requirement); otherwise proceed as described under **Checking the Absolute Accuracy**. The averaged trace must lie within the tolerance band shown in the graphical display. The tolerance limits are considerably tighter than would be the case for a normal R&S®NRV-Z51 sensor. If the trace is shifted uniformly upward or downward over all of the frequency range, this indicates drift of the DC voltage parameters of the power standard or the verification sensor (see section **DC Voltage Tests**)
- Switch the reference attenuator to the output of the power standard (Fig. 2-11) and repeat the check with the R&S®NRV-Z1 sensor from the verification set. In this case too, the averaged trace must lie within the tolerance band. The tolerance limits are also considerably tighter than would be the case for a normal R&S®NRV-Z1 sensor. Minor changes in the trace may occur if the generator is changed (harmonics)
- Prepare the test setup for checking the linearity as shown in Fig. 2-24
- Perform a linearity check using the two sensors from the verification set (see section **Checking the Linearity**). The traces must remain within the tolerance bands shown in the graphical display

Note: *The model code stored in the data memory of the verification sensors is "88" (ignore the code on the type plate). This makes it possible to distinguish the sensors from the normal sensors of the same type. It is not possible to accidentally overwrite the data memory contents.*

DC Voltage Tests with the R&S®NRVC Calibration Kit

The objective of the measurements is to check the characteristics of the power standard, reference attenuator and R&S®NRV-Z51 verification sensor for DC voltages and to use correction factors to eliminate the effects of drift due to aging or ambient conditions. The set of correction data is stored in an editable calibration program file so that it can be cleared at any time as required and the incoming status restored. The correction data can be activated only in conjunction with **R&S®Recal+**. The menu-driven measurements are performed on a measurement setup as shown in Fig. 4-1. The individual measurement setups are listed in Table 4-1.

The first step is to connect the precision DC termination ⑦ to the output of the power standard and then perform zeroing. Next, measure the voltage drop across the built-in 50 Ω resistor by using a digital voltmeter. Based on the calculated output power and the power measured by the R&S®NRVC, the correction factor K_{NRVC} is obtained.

The correction factor for the reference attenuator ②, referred to as K_{ATT} , can be obtained in the same manner. To perform this measurement, connect the reference attenuator between the power standard and the DC termination. Finally, connect the R&S®NRV-Z51 sensor from the verification set to the output of the power standard. Based on the measured values of the power standard, verification sensor and correction factor K_{NRVC} , the K_{Z51} correction factor is obtained.

Since the sensitivity of the thermal sensors in the R&S®NRV-Z51 and the power standard is polarity-dependent, all measurements are made with positive as well as negative feed voltage and the arithmetic mean is used when calculating the correction factors.

Ideally, all three correction factors should be 1 since a DC calibration of the individual components was performed when the R&S®NRVC was calibrated. Deviations may be due both to ambient conditions and the base unit that was used. During verification, it is best to connect the power standard to the R&S®NRVD measurement channel that will also be used for the power standard when the R&S®NRVC is used later on.

Note: To calculate the power that was converted in the DC termination ⑧ on the basis of voltage measurements the termination must contain a high-precision 50 Ω resistor. The built-in resistor therefore meets a very tight tolerance requirement (±0.01 %) and has only a minimum effect on the measurement results. Nevertheless, the resistor should be occasionally checked with a multimeter. The termination should equal $50\Omega \pm 0.015\Omega$. A four-pole resistance measurement should be performed (see opposite figure).

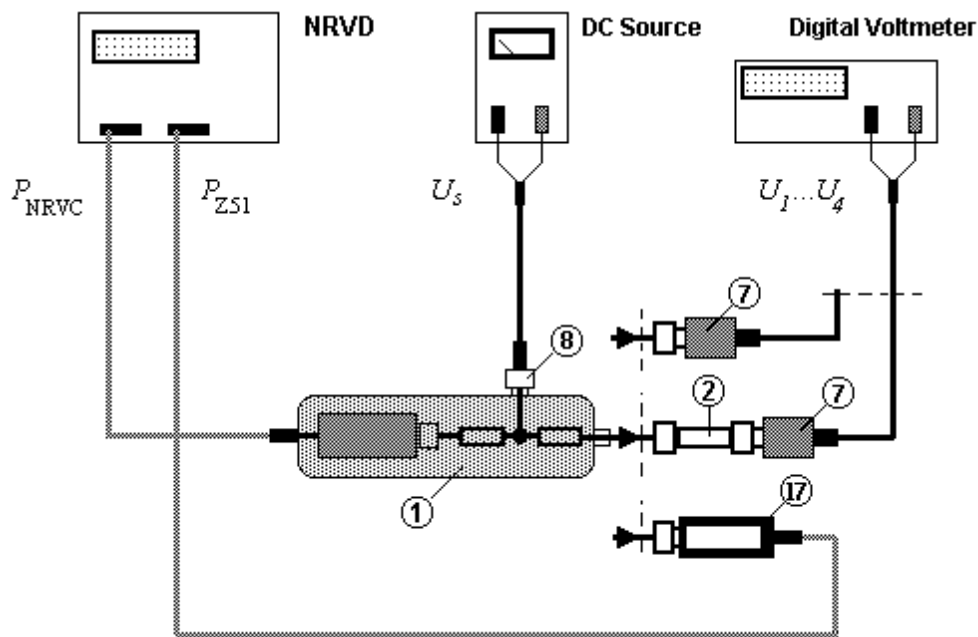
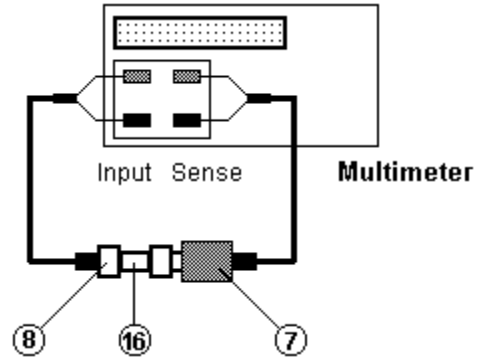

Fig. 4-2 Test setup for checking the calibration kit with DC voltage.

Additional measuring equipment required

DC source: Stable DC voltage source with an output voltage of 0.45 V into 50 Ω. At a load of 50 Ω, the output voltage should not vary by more than ± 0.01 % from the mean value.

Digital voltmeter: 5½ digits with a resolution of at least 1 μV at a measured voltage of 22 mV or 1 mΩ at a resistance of 50 Ω. The measurement uncertainty should not be greater than 0.01 % for DC voltage measurements. The settings for the averaging filter and/or integration time need be selected such that the display is stable. Select autoranging.

Table 4-1 Measurement steps for verification with DC voltage

Item no.	Feed voltage V_s	Attenuator ②	Meas. power for R&S®NRVC (approx.)	Meas. voltage V (approx.)	Meas. power for R&S®NRV-Z51 (approx.)
1	+0.45 V	Not fitted	$P_{NRVC,1}$ (1 mW)	V_1 (+0.225 V)	-----
2	-0.45 V	Not fitted	$P_{NRVC,2}$ (1 mW)	V_2 (-0.225 V)	-----
3	+0.45 V	Fitted	$P_{NRVC,3}$ (1 mW)	V_3 (+0.022 V)	-----
4	-0.45 V	Fitted	$P_{NRVC,4}$ (1 mW)	V_4 (-0.022 V)	-----
5	+0.45 V	Not fitted	$P_{NRVC,5}$ (1 mW)	-----	$P_{Z51,5}$ (1 mW)
6	-0.45 V	Not fitted	$P_{NRVC,6}$ (1 mW)	-----	$P_{Z51,6}$ (1 mW)

Measurement procedure

- Allow the test setup shown in Fig. 4-1 to warm up for at least an hour. Do not forget to connect the ⑰ verification sensor to the R&S®NRVD
- Launch **R&S®Recal+** and select the **DC Correction...** dialog in the **Options** menu

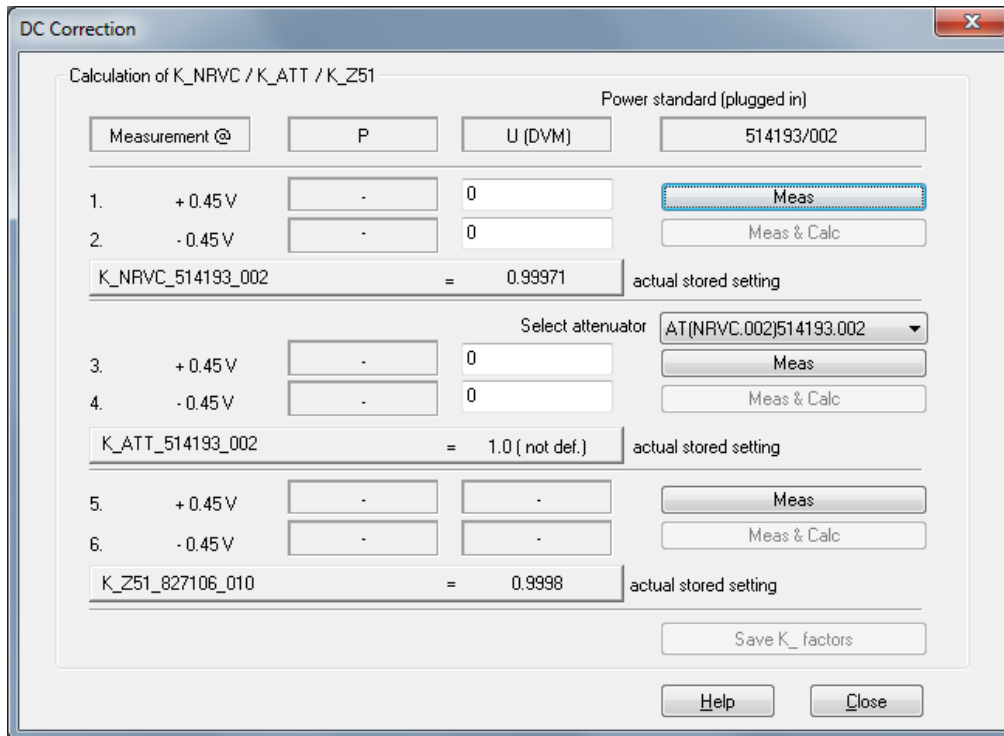
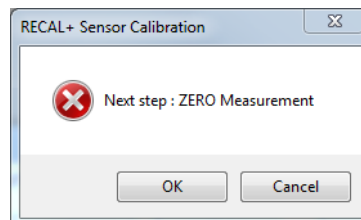

Fig. 4-3 Dialog box for checking the R&S®NRVC with DC voltage

- The **DC Correction** dialog box allows interactive measurement. Perform measurements in the sequence specified in (Table 4-1)

Calculating correction factor K_{NRVC}

- Connect the precision DC termination – without attenuator – directly to the output of the power standard
- Press the **Meas** button (1. in the DC Correction dialog box): You will now be prompted to confirm that you want to prepare for zeroing



- If a DC calibrator is used, set the output voltage to 0 V. Otherwise, remove the two banana connectors on the connecting cable from the source and short-circuit them
- Start manual zeroing on the digital voltmeter

- Press the **OK** button. Zeroing is performed for the power standard on the R&S®NRVD
- After you complete zeroing, you will be prompted to confirm that you want to prepare for measurement with +0.45 V

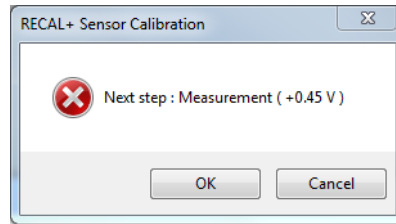

- Plug the connecting cable into the source again and set the output voltage to +0.45 V
- Press the **OK** button: The power applied to the R&S®NRVC is measured, and the measured value is shown in the **P** field of step 1

- Measure the voltage drop at the DC termination using the digital voltmeter and enter the measured value into the **U** field of step 1
- Set the output voltage to –0.45 V on the DC source (or interchange the connectors of the connecting cables)

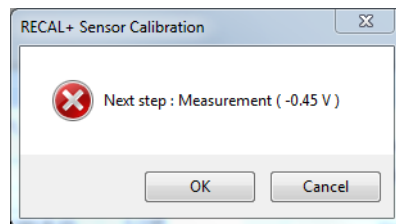

- Measure the voltage drop at the DC termination using the digital voltmeter and enter the measured value – with negative sign – into the **U** field of step 2
- Press the **Meas & Calc** button
- Press the **OK** button
- The power applied to the R&S®NRVC is measured and the measured value is shown in the **P** field of step 2. The new correction factor K_{NRVC} is displayed
- Switch off the output voltage of the DC source

Calculating correction factor K_{ATT}

- Insert the reference attenuator between the power standard and the DC termination
- In the **Select attenuator** panel, select the file that matches the attenuator (file name identical to serial number)
- Press the **Meas** button and proceed as described above. Do not forget to perform new zeroing for the digital voltmeter

Calculating correction factor K_{Z51}

- Connect the R&S®NRV-Z51 verification sensor to the output of the power standard
- Wait five minutes and then press the **Meas** button. Now proceed as described for the other measurements

Saving correction factors

- Press the **Save $K_{factors}$** button
- The correction factors will be saved under the CALIBRATION heading in the **recal.ini** initialization file located in the Windows directory

```
[CALIBRATION]
K_NRVC_874332_003 = 0.99898
K_ATT_874334_003 = 1.00070
K_Z51_875224_003 = 0.99740
```

5 Recalibration

It is recommended to return the R&S®NRPC (R&S®NRVC) and the options to Rohde & Schwarz for recalibration once a year. As part of recalibration, all components are checked, and the reference standards, the reference attenuators and the precision termination are recalibrated. The sensors from the verification set are adjusted to match the recalibrated standards and the data memories are updated.

If you need a recalibration done, contact your nearest Rohde & Schwarz representative. Please send in the complete calibration kit packed in its storage cases.

Procedures to be Performed after Recalibration

When you receive the calibrated kit, perform the following procedures to ensure that it is functioning correctly:

- Perform a software update (if mentioned in the accompanying letter). The update is like an initial installation, but all directories, measurement files, EPROM files and user-specific information in the **recal.ini** file are retained. Before launching the setup program, uninstall the current version (use the **Uninstall** program from the **R&S Recal+** program group)

R&S®NRPC calibration kit

- Connect the R&S®NRPC power standard to one channel of the R&S®NRP2
- Launch the **R&S®Recal+** calibration software
- Initialize the R&S®NRP2
- Perform the verification as described under **Verification of the R&S®NRPC Calibration Kit**

R&S®NRVC calibration kit

- Copy the contents of the ③ **CALIBRATION DATA** data disk into directory **...\\recal\\config.dat** (if not already done during a previous software update)
- Connect the R&S®NRVC power standard and the R&S®NRVC-B2 linearity standard each to a channel of the R&S®NRVD
- Launch the calibration software
- Initialize the R&S®NRVD, power standard, linearity standard, reference attenuator and precision termination (see instructions at beginning of **Sensor Calibration** section)
- Perform the verification as described under **Verification of the R&S®NRPC Calibration Kit**. If you choose not to perform verification, set the correction factors $K_{NRVC...}$, $K_{ATT...}$ and $K_{Z51...}$ in the **recal32.ini** file to 1.0 or delete these entries

6 Appendix

Exchanging the RF Connector on the Test Port of the Power Standard

In the R&S[®]NRPC33, R&S[®]NRPC40 and NRPC50 power standards, there is an adapter between the test port and the output of the integrated power splitter which can be exchanged by the user if the test port's RF connector becomes worn out. A replacement adapter ⁽²¹⁾ is supplied for this purpose with each of the calibration kits mentioned here. To ensure the accuracy level is retained even after the adapter is exchanged, each power standard is calibrated with both adapters during manufacture and recalibration at German Accreditation Body (DKD) laboratory D-K-15195-01-00. The calibration certificate contains the calibration data for both configurations.

The adapter should be exchanged if the test port is obviously damaged as well as in the following cases:

- Verification with the R&S[®]NRPC-B1 verification sensor fails due to strong oscillations in the frequency response
- High dependence on the angular position during calibration of absolute accuracy

The following table describes the procedure used to exchange the adapter along with the subsequent steps that are required:

Table 6-1 Exchanging the RF connector on the test port

Item no.	Work step	Comments
1	Remove the anti-turn device for the adapter's hex nut (this involves loosening two grub screws)	Allen wrench (wrench opening 0.9 mm)
2	Unscrew the adapter	Flat wrench (wrench opening 8 mm)
3	Screw on the replacement adapter ⁽²¹⁾ , tighten the hex nut with a torque of 1.5 Nm	Torque flat wrench (wrench opening 8 mm) with a torque of 1.5 Nm
4	Slide on the anti-turn device and tighten the grub screws	
5	Install the R&S[®]NRP-Toolkit software	On CD-ROM ⁽³⁾
6	Connect the power standard to the USB port of a Windows computer	Requires USB adapter R&S[®]NRP-Z3 or R&S[®]NRP-Z4 or sensor hub R&S[®]NRP-Z5
7	Load the power standard's calibration data set for the replacement adapter ⁽²¹⁾	With program module <i>Firmware update</i> from R&S[®]NRP-Toolkit
8	Connect verification sensor to USB port of a Windows computer	
9	Load the calibration data set for the verification sensor for use on a power standard with the replacement adapter ⁽²¹⁾	With program module <i>Firmware update</i> from R&S[®]NRP-Toolkit
10	Connect power standard and verification sensor to R&S[®]NRP2 base unit	
11	Check identification of the loaded calibration data sets	
12	Verification measurement	

- Re 3: The torque of the supplied torque wrench (0.9 Nm) is too small to prevent the adapter from turning during subsequent usage. If a suitable torque wrench is not available, tighten the adapter somewhat tighter by feel and then check whether the adapter turns when the sensor is screwed on and off.
- Re 7: The calibration data for the power standard must also be exchanged when the adapter is exchanged. The data set called ***Caldata_NRPC_T<serial no.>.nrp*** is located on the data CD ③ in the ***Dataset/Exchange_Thru*** directory. The serial number at the end of the file name refers to the spare adapter. This number is also engraved on the adapter.

Fig. 6-1 shows the user interface for the ***Firmware-Update*** program module of the ***R&S®NRP-Toolkit***. After clicking the Browse button, select the calibration data set for the power standard in the above-named directory and start the download by clicking the Start key.

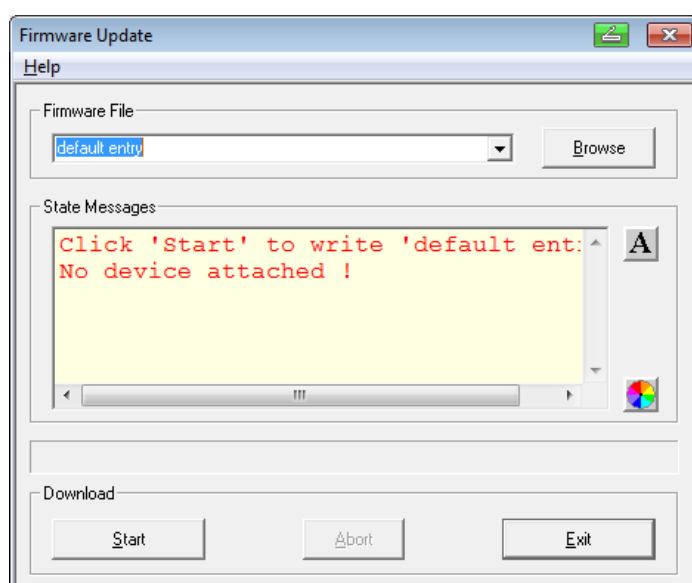

Fig. 6-1 User interface for ***Firmware Update*** from the NRP-Toolkit

- Re 9: The calibration data set for the verification sensor must also be exchanged in order to obtain correct verification results from the start. The calibration data set is called ***Caldata_NRPC-B1_T<serial no.>.nrp*** and is also located on the data CD ③ in the ***Dataset/Exchange_Thru*** directory. As before, the serial number at the end of the file name refers to the spare adapter.
- Re 11: After successfully loading the calibration data sets, the serial number of the spare adapter should appear in info texts in the R&S®NRP2 base unit (in the ***System*** menu under ***Sensor Info: SPD Mnemonic***).

For the power standard, the letter ***T*** should be followed by the serial number engraved on the spare adapter, e.g. ***T12387*** in the entry ***T12387***. An additional code ***A####*** stands for the supplied reference attenuator in the case of the R&S®NRP33 and R&S®NRP40 calibration kits.

- Re 12: The measured values must lie well within the specified tolerance bands. If this is not the case, check whether the correct calibration data sets were actually loaded. Otherwise, unscrew the adapter and try remounting it in a different angular position.

Measurements on a Separate Measurement Setup

All of the measurements (reflection, absolute accuracy and linearity) can also be performed on separate measurement setups. The measurement results must then be transferred in the form of standard ASCII files to **R&S®Recal+** for further processing. The required measurement frequencies and levels for each type of sensor are stored in a configuration file.

The configuration files are stored in the `...recal/config.dat` directory and can be read with any standard text editor. The file name consists of the type designation of the sensor and the three-digit model code (padded on left with zeros). For example, for an R&S®NRV-Z1 sensor with material number 0828.3018.03 (5 m connecting cable), the file name is `nrv-z1.003`.

The measurement results are to be stored in the `...recal/measure.dat` directory in an ASCII file whose name consists of a header (**rf**: reflection; **ln**: linearity; **fr**: absolute accuracy; **sp**: S-parameter for attenuators) and the serial number of the sensor. The structure of these files is shown in Table 6-4 to Table 6-10: All mandatory entries are in bold, and all user-specific entries in normal font. The column on the right explains the various entries (i.e. these explanations are not included in the files).

Reflection

There are the following possibilities for the reflection measurement:

- Program-controlled measurement and transfer of the measurement data using the **R&S®ZVX_RECAL** additional program belonging to the **R&S®Recal+** software in conjunction with selected network analyzers from Rohde & Schwarz
- Manual or program-controlled measurement with any other suitable network analyzer and further processing of the measurement data based on one of the two following possibilities:
 - Creation of one file each with the reflection and measurement uncertainty data in Touchstone format and subsequent import of these files using **R&S®Recal+**
 - Manual creation of a single file with reflection and measurement uncertainty data in a format compatible with **R&S®Recal+** and storage of this file in the `...\\Recal+\\measure.dat` directory

Program-Controlled Reflection Measurement with **R&S®ZVX_RECAL**

After the program is successfully installed, the **Measurement with NRVC/NRPC** dialog (after pressing the  button) should have the **Reflection / S Parameter** tab (Fig. 6-2). From there, the network analyzer and DUT are selected and the test program is launched.

Table 6-2 contains a list of the individual steps in a reflection measurement. Further details of the individual steps are discussed below.

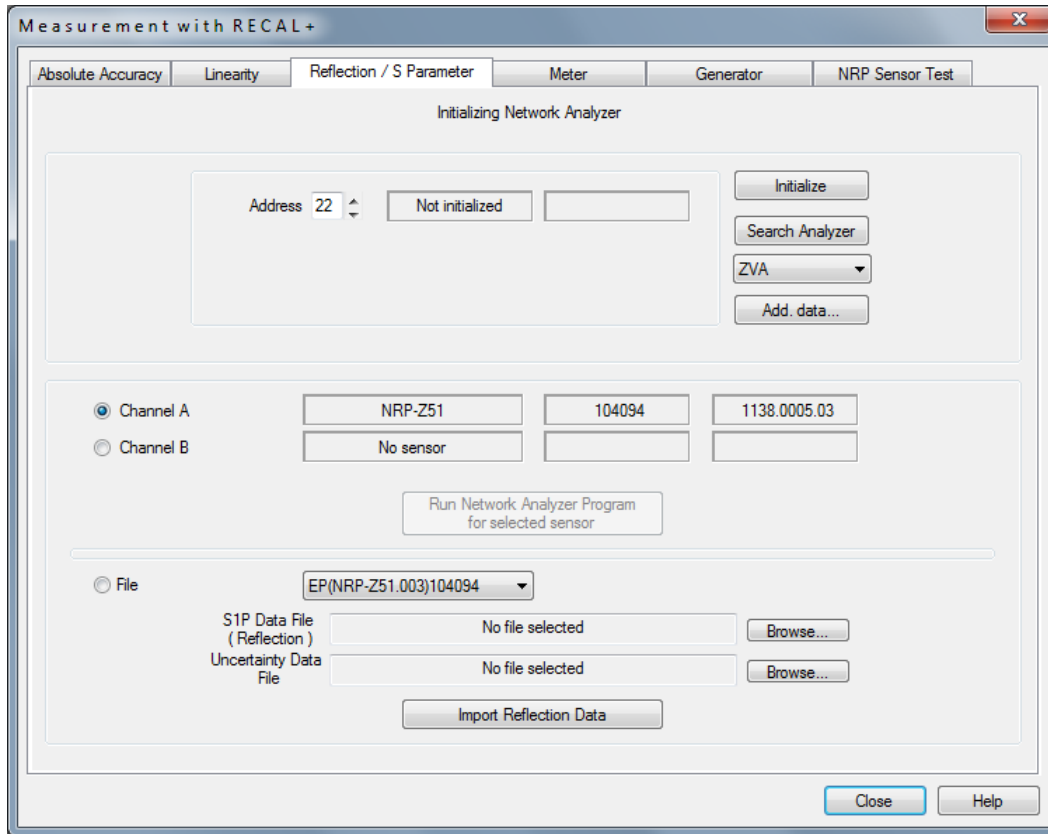

Fig. 6-2 Reflection / S Parameter tab

Table 6-2 Reflection measurement

Item no.	Work step	Location	Comments
1	Read in calibration kit		
2	Connect network analyzer to test system via IEC/IEEE bus	Network analyzer	
3	Launch R&S®Recal+ software		
4	Initialize vector network analyzer		
5	Select sensor	Dialog Reflection / S Parameter	Channel A or channel B on basic power meter
6	Launch R&S®ZVX_RECAL software		Button Run Network Analyzer Program for selected sensor
7	Calibrate vector network analyzer		The network analyzer's calibration is stored for subsequent reuse
8	Measure DUT's reflection	Dialog ZVX_RECAL	It is recommended to check the sensor's immunity from mounting the connector in a different angular position by connecting it multiple times
9	Return to R&S®Recal+		Button Quit

- Re 1: Prior to starting the measurements, the data for the selected calibration kit(s) should already be saved in the network analyzer
- Re 4:
 - Select the type of network analyzer that is connected
 - Use the **Search Analyzer** dialog to search for the GPIB address of the connected instrument. If the GPIB address is known, it can be entered into the **Address** field and the search skipped
 - Initialize the network analyzer
- Re 6: - The **R&S®ZVX_RECAL** software starts up in its own window

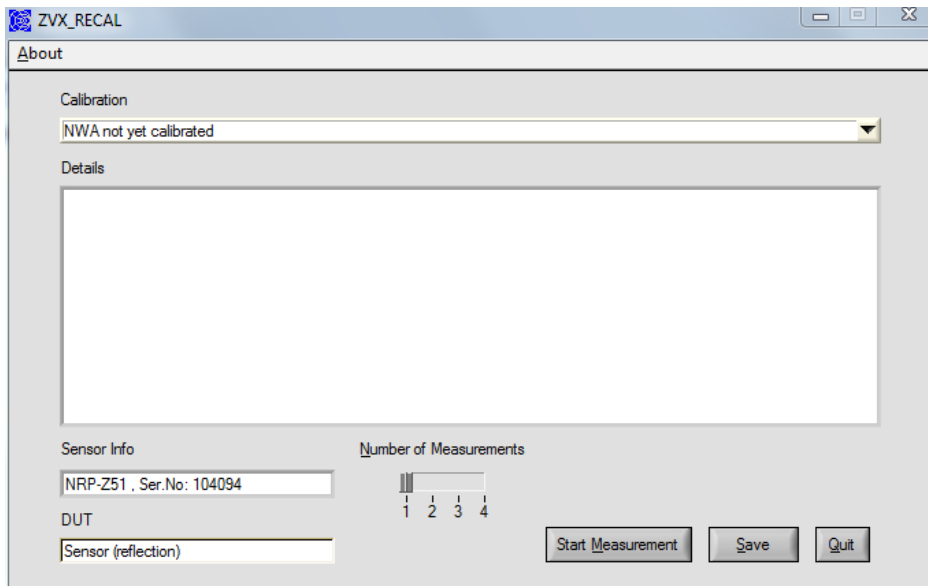

Fig. 6-3 **R&S®ZVX_RECAL** user interface immediately after start-up

- Re 7:
 - In the **Calibration** drop-down list, select the **New: One Port OSM** entry. A window like the one shown Fig. 6-4 will open
 - Select an appropriate calibration kit in the **active Cal Kit** list. The list only shows the calibration kits that are suitable for the DUT's connector
 - Initiate the calibration by pressing the **Start** button. A window like the one in Fig. 6-5 will appear with a prompt to connect the first calibration standard
 - Connect the requested calibration standard (check the serial number!) to the network analyzer and click the **Continue** button
 - Proceed in the same manner for the other calibration standards
 - Confirm the **Calibration complete** message with **OK**. The **R&S®ZVX_RECAL** user interface will reappear in the foreground (Fig. 6-6)

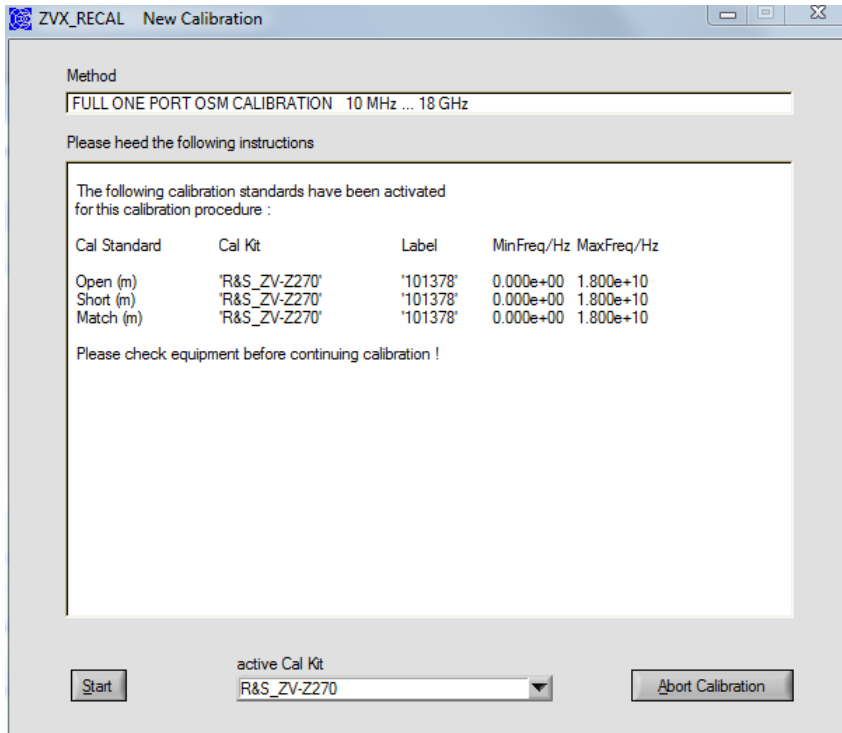

Fig. 6-4 Window for selection of the calibration kit

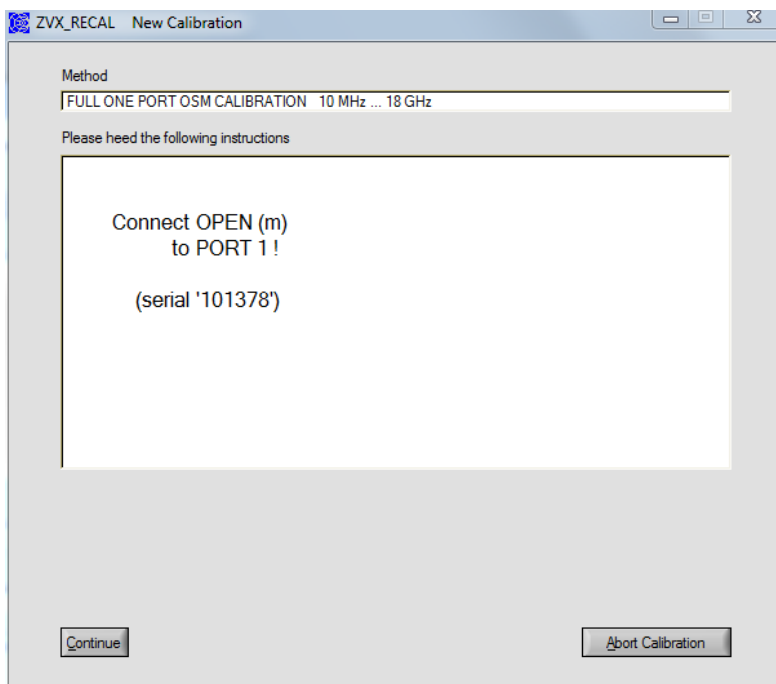

Fig. 6-5 Prompt to connect the first calibration standard

- Re 8:
- Select the number of measurements in the **Number of Measurements** field
 - Press the **Start Measurement** button
 - Connect the DUT to the network analyzer and confirm the procedure (Fig. 6-7)
 - The measurement should begin. After it is completed, the measurement result is displayed graphically (Fig. 6-8)
 - Press the **Continue** button. Depending on the number of set measurements, there is either another prompt to connect the DUT (in another angular position) or the **R&S® ZVX_RECAL** user interface will appear with the **Measurement complete!** message (Fig. 6-9)
 - Press the **Save** button. An average measurement result is formed from the individual measurements and saved as a file named **rf (<type designation> <serial no.>** in the **...\\recal+\\measure.dat** directory
- Re 9:
- Return to the **R&S® Recal+** user interface by pressing the **Quit** button

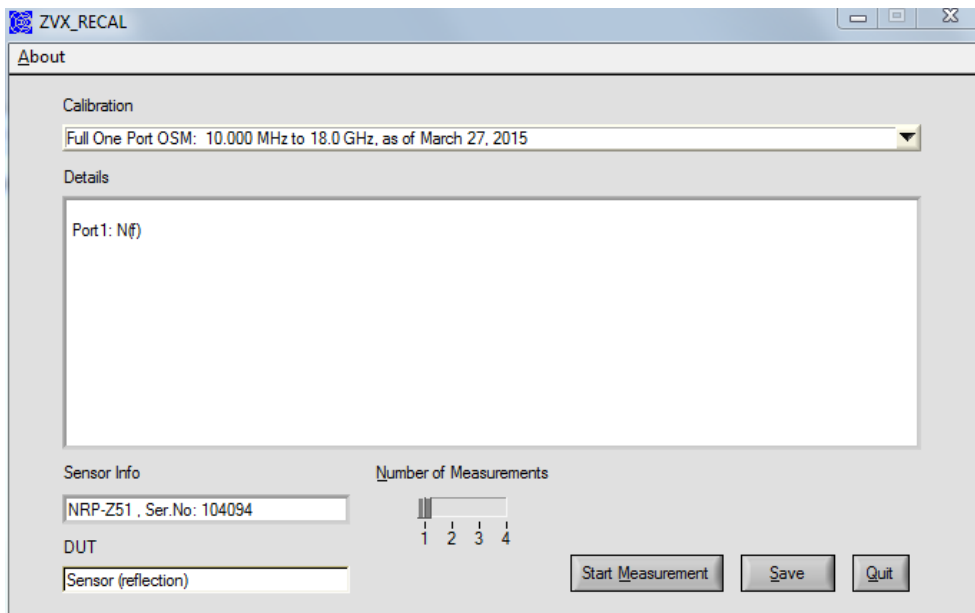

Fig. 6-6 User interface for calibrated network analyzer



Fig. 6-7 Prompt to connect the DUT



Fig. 6-8 Graphical display of the reflection measurement results

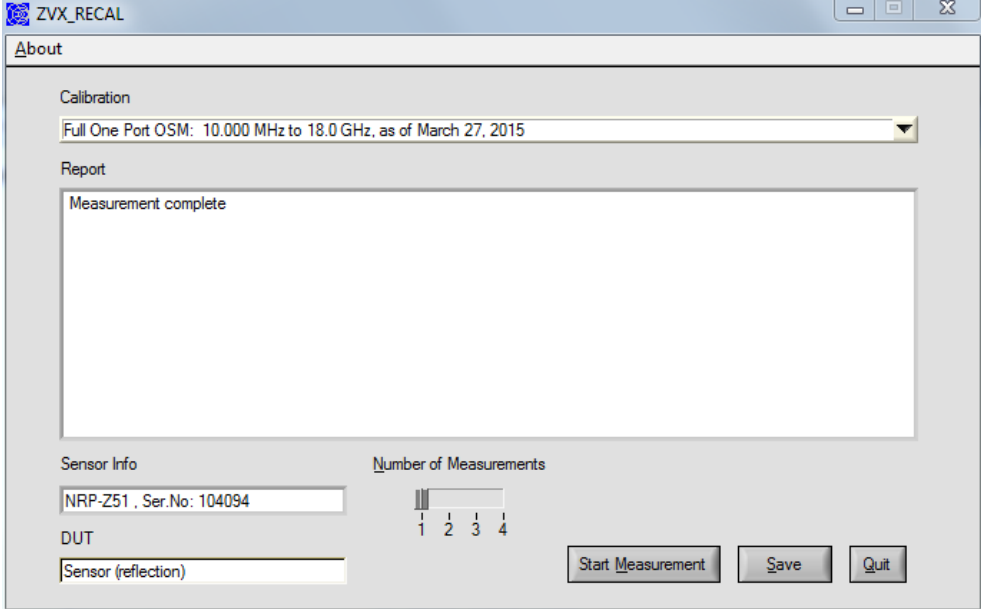

Fig. 6-9 User interface after completed reflection measurement

Information about reflection measurements with R&S® ZVX_RECAL

Frequency range and number of frequencies

Both parameters are set solely as a function of the connector type. This means that sensors with identical connectors are adjusted at the same frequencies. This has a significant benefit in that only a single calibration is required per connector type. The measurement points that are not necessary for the sensor between its upper frequency limit and the maximum frequency of the respective connector type are automatically discarded during subsequent evaluation of the measurement data. A standard value of 10 MHz is used as the lower frequency limit.

Validity of the calibration

The network analyzer's calibration is stored with the date. If multiple DUTs with the same connector type are adjusted in sequence, the network analyzer's calibration can be reused. The user only needs to ensure that the system data (directivity, reflection tracking and source match of the network analyzer) have not changed significantly. Changes generally occur due to drift of the network analyzer vs. time or changes on the network analyzer's test port. In case of any doubt, perform a new calibration using **New: One Port OSM (User)**.

Measurement uncertainty

Reflection measurements on power sensors are influenced primarily by the accuracy of the calibration kit and the stability of the network analyzer, and only then by the reflection of the actual sensor. The measurement uncertainty can be generalized as follows:

$$U = a + b \cdot |r|$$

The term *a* is independent of the measurement result and is primarily a function of the effective directivity. On the other hand, the term *b* takes into account the effective reflection tracking and the effective source match. Since power sensors generally exhibit very good matching, the influence of *b* tends to be small.

When computing the measurement uncertainties, the **R&S® ZVX_RECAL** program module makes use of the values listed in Table 6-3 for the term *a*. They are valid when using the recommended calibration kits (Table 2-13). For *b*, a conservative estimate of 0.04 is used in all cases.

Table 6-3 Expanded measurement uncertainties (*k* = 2) for a well matched DUT (term *a*)

Frequency range	N (50 Ohm)	3.5 mm	2.92 mm	2.4 mm
DC to 0.1 GHz	0.005	0.005	0.005	0.005
> 0.1 to 2.4 GHz	0.005	0.005	0.005	0.005
> 2.4 to 8.0 GHz	0.005	0.007	0.007	0.007
> 8.0 to 12.4 GHz	0.005	0.009	0.009	0.009
> 12.4 to 18.0 GHz	0.006	0.009	0.009	0.010
> 18.0 to 26.5 GHz	---	0.011	0.011	0.014
> 26.5 to 33.0 GHz	---	0.011	0.011	0.015
> 33.0 to 40.0 GHz	---	---	0.011	0.015
> 40.0 to 50.0 GHz	---	---	---	0.017

At low frequencies, vector network analyzers tend to exhibit a large, system-related statistical uncertainty. To reduce this uncertainty, **R&S® ZVX_RECAL** sets the bandwidth of the network analyzer accordingly. In addition, the measurement result for the 10 MHz frequency point is determined based on measurement results for multiple frequency points in the immediate vicinity of 10 MHz. Both steps help to considerably reduce stochastic error influences.

Storage of the measurement result

The measured reflection coefficients are stored along with the measurement uncertainties as well as general information in the `...reca/measure.dat` directory. The file contains only the frequency points that are relevant for the applicable sensor. The file name is structured as follows:

rf (<type>) <serial no.>

For a sensor of type R&S® NRV-Z15 with serial number 102972, it would be as follows:

rf(NRP-Z21)102972

Reflection measurement without using R&S® ZVX_RECAL

If the network analyzer used for the reflection measurement is not supported by the R&S® Recal+ software (supported network analyzers are listed in Table 2-10 and Table 2-11), the user is responsible for ensuring that the measurement is properly configured and the measurement data is stored in a format that is compatible with the R&S® Recal+ software.

Configuration of the Network Analyzer

All of the necessary information is saved in the configuration file for the sensor to be calibrated. The configuration files are stored in the ...**recal+config32.dat** directory and the file name contains the type designation and variant identifier of the sensor. They are created in ASCII format and can be read using any standard editor. Fig. 6-10 shows parts of the configuration file for the R&S® NRV-Z15 CW power sensor which is representative of all of the sensors with only a single measurement path in this context.

Measurement level for calibration of absolute accuracy →

Measurement frequencies for calibration of absolute accuracy and matching →

Specified reflection coefficients →
 50 MHz to 4 GHz ≤0.07
 > 4 GHz to 40 GHz ≤0.157

```
freqLevel= 1.0E-6
...
frequencyresponse=
  50E6 , 1.0
  100E6 , 1.0
  500E6 , 1.0
  ...
  40E9 , 1.0
DataBlockEnd
...
reflectionCoefficients=
  50E6 ,0.070
  4.05E9 ,0.157
DataBlockEnd
...
```

Fig. 6-10 Excerpt from configuration file *nrv-z15.002* for R&S® NRV-Z15 sensor type with variant identifier 02

The exact measurement level in the reflection measurement is not critical in the case of a thermal sensor or if the measurement data is not used for gamma correction of the calibration of absolute accuracy. Otherwise, it should be as large as the value used for calibration of absolute accuracy. This value is saved in the configuration file under the "**freqLevel**" entry and has the unit of W for a power sensor. In case of values under 10 µW (-20 dBm), the reflection measurement may be performed with no problem at a measurement level of -20 dBm since reflection changes hardly occur in case of further level reduction. The measurement time is selected such that the measurement uncertainties resulting from the measurement noise remain small with respect to the error influences which are due to the network analyzer's calibration. The values in Table 6-3 can be used as a starting point for the total measurement uncertainty.

In the case of multi-path sensors, multiple level specifications are present, depending on the number of paths, under the "**freqNpathLevel**" entry. Here, use the second entry which is generally identical for two-path sensors with the measurement power for the first path and for three-path sensors with the measurement power for the third path.

The measurement frequencies are listed under the "**frequencyresponse**" entry. The values specified there apply for calibration of absolute accuracy as well as for the reflection measurement, and measured values must be available for these frequencies. In order to be able to define simply structured sweeps, it might be necessary to make measurements at other frequencies besides the listed ones. The R&S® Recal+ software is configured for this and will accept such additional frequency points (but only for the reflection measurement).

The measurement data is best saved as a Touchstone file in the *.s1p format for easy further processing (see next section).

The configuration files for the sensors also include the limits specified in the data sheet for the magnitude of the linear reflection coefficient. These specifications are listed in the table under the "reflectionCoefficients" entry. The left column contains in each case the frequency starting at which the limit specified in the right column is valid. The value in the last row is logically valid up to the sensor's upper frequency limit. With the R&S®URV5-Z2 and R&S®URV5-Z4 voltage sensors, the reflection is measured at the male connector end; the female connector must be terminated with the precision termination Ⓢ.

Formatting and Saving the Reflection Measured Values

In order for the network analyzer's measurement data to be evaluated by the **R&S®Recal+** software, the data must be saved in the form of an "RF file" in the ...**recal+measure.dat** directory. Here, there are two possibilities:

- Creation of one ASCII file each with the reflection and measurement uncertainty data in Touchstone format and subsequent import of these files using the **R&S®Recal+** software
- Manual creation of a single ASCII file with reflection and measurement uncertainty data in a format compatible with **R&S®Recal+** and storage of this file in the ...**recal+measure.dat** directory

Importing reflection and measurement uncertainty files

This is generally the simpler of the two possibilities since most network analyzers are capable of automatically generating measurement data in Touchstone format. Then, the user only needs to create the measurement uncertainty file with its very simple format and perform the data import. The import procedure requires prior installation of the **R&S®ZVX_RECAL** additional program (see start of chapter3).

Details on the content and format of the two files can be found further below. The individual work steps needed to import the data are as follows:

- Save the network analyzer's measurement data on a storage medium that the **R&S®Recal+** software can access
- Create the measurement uncertainty file and save it on a storage medium that the **R&S®Recal+** software can access
- Launch the **R&S®Recal+** software and call up the **Measurement with NRVC/NRPC** dialog using the  button in the toolbar
- Select the **Reflection / S Parameter** tab
- Select the sensor that the reflection data is associated with. If this sensor is connected to an initialized base unit, click the corresponding radio button. Otherwise, click the "File" radio button and select the sensor from the list that appears. Of course, the second possibility assumes that the sensor has been plugged in at least once and its data was read out
- Select the file with the network analyzer's measurement data. To do this, click the **Browse** button in the **S1P Data File (Reflection)** field
- Select the measurement uncertainty file. To do this, click the **Browse** button in the **Uncertainty Data File** field
- Click the **Import Reflection Data** button. Now, **R&S®Recal+** automatically generates a file in the "RF" format based on the two starting files and saves it in the ...**recal+measure.dat** directory. The file name consists of the sensor's type designation, its variant identifier and the serial number

Structure of a file to import the network analyzer's measurement data

The reflection coefficients measured at the individual frequencies must be saved with the real and imaginary parts in the Touchstone format (*.s1p) (Fig. 6-11). A period must be used as a decimal separator. The header indicated with # must contain all of the information needed to interpret the data, i.e. the frequency unit (HZ|KHZ|MHZ|GHZ), identification of S-parameter data (S), data format real/imaginary (RI) and reference impedance of 50 Ω (R 50). Comments can be inserted directly after the header following an exclamation point (!). Except for the mandatory file extension "s1p", any desired file name can be used.

```
# HZ S RI R 50
! Rohde & Schwarz ZVA/B
!
! Frequency      Real part      Imaginary part
1.00000E+07     1.57630E-03   -2.22580E-03
5.00000E+07     1.37430E-03   -4.56010E-04
1.00000E+08     8.08320E-04   -1.36200E-04
3.00000E+08     1.45920E-04   -2.67880E-04
....
....
```

Fig. 6-11 ASCII file with reflection data in Touchstone format *.s1p

Important: Reflection coefficients must always be saved with the real and imaginary parts. Other formats are not supported.

Structure of a file with the uncertainties of the reflection measurement

The expanded linear uncertainties with k = 2 are to be saved as a function of the frequency. A period must be used as a decimal separator. The left column contains in each case the frequency starting at which the measurement uncertainty specified in the right column is valid. The value in the last row is logically valid up to the sensor's upper frequency limit. In most cases, only a few entries are needed, and the measurement uncertainty file can be applied universally. The header indicated with # only needs to contain the frequency unit used in the table (HZ|KHZ|MHZ|GHZ) and the identifier for the measurement uncertainty file (U). Comments can be inserted directly after the header following an exclamation point (!). Any desired file name can be selected.

```
# HZ U
!
! Frequency      Uncertainty (k=2)
1.00E+07         0.005
2.41E+09         0.007
8.01E+09         0.009
12.41E+09        0.010
```

Fig. 6-12 ASCII file with measurement uncertainties

Creating, editing and saving a file in "RF" format

Measurement files in "RF" format contain all of the information needed for matching of a sensor. Besides the measurement data and measurement uncertainties, they also contain information about the sensor and calibration. Table 6-4, Table 6-5 and Table 6-6 show examples of the format and content of these files. The three examples differ in terms of how the reflection measured values are presented. The preferred format with all of the necessary information is shown in Table 6-5. If the measurement data is available only in scalar form and can thus be used only for reporting and for computing the mismatch uncertainty in the calibration of absolute accuracy, use the format in Table 6-6. A file like the one in Table 6-4 has the same information content as one in the preferred format, but it also includes the magnitudes of the reflection coefficients.

Files in the "RF" format must be saved in the `...\\recal\\measure.dat` directory. The file name must contain the type of the sensor and its serial number in the following format:

rf (<type>) <serial no.>

For a sensor of type R&S® NRV-Z15 with serial number 102972, the file name would be as follows:

rf(NRP-Z21)102972

It is sometimes helpful to edit an "RF" file created by R&S® *Recal+* (after importing the Touchstone and measurement uncertainty file) in order to enter information that is not contained in the original files. This includes information about the measuring instruments that were used, the name of the technician and data on the temperature and humidity (see Table 6-4 to Table 6-6).

Table 6-4 Measurement file *rf(NRP-Z21)102972* for checking reflection (NRP sensors, variant 1)

<pre>[SENSOR-MEAS-DATA-FILE] CalDataType = REFLECTION_DATA DeviceList = "VNA, HP, 8510, 8430F9241, 199710A4435, 1998-05" "..." DataBlockEnd TestEngineer = "Peter Schmidt" Humidity = "40 to 60" // % r.H. Temperature = "20 to 25" // °C SerialNo = "102972" StockNo = "1081.2305.02" SensorType = "NRP-Z11" Date = "2004-05-12" DataPoints = 45 ValuesPerPoint = 5 Value = // Reflection coefficient of DUT // f/Hz Magnitude Uncert. Real part Imaginary part 5.000E+7 0.8783E-1 0.40E-2 0.7350E-1 0.4808E-2 1.000E+8 0.2650E-1 0.40E-2 0.1584E-2 0.2645E-1 5.000E+8 0.9632E-2 0.40E-2 0.2937E-2 0.9173E-2 8.000E+9 0.32506E-1 1.20E-2 0.1742E-2 0.3245E-1 DataBlockEnd</pre>	<p><i>Designation as measurement file</i></p> <p><i>Designation as reflection data</i></p> <p><i>List of measuring devices; a separate line is to be provided for each component:</i></p> <p><i>"<designation>, <manufacturer>, <type>, <serial no.>, <certificate no.>, <calibration expiry date>"</i></p> <p><i>The list must be terminated with DataBlockEnd.</i></p> <p><i>Name of test engineer</i></p> <p><i>Rel. humidity in %</i></p> <p><i>Comment line</i></p> <p><i>Temperature range in °C</i></p> <p><i>Comment line</i></p> <p><i>Serial number</i></p> <p><i>Material number</i></p> <p><i>Type designation</i></p> <p><i>Calibration date (12 May 2004)</i></p> <p><i>Number of frequencies</i></p> <p><i>Number of values per measurement point</i></p> <p><i>Assignment of calibration values</i></p> <p><i>Comment line</i></p> <p><i>Comment line</i></p> <p><i>List of values, with columns separated by at least one space.</i></p> <p><i>The list must be terminated with DataBlockEnd.</i></p> <p><i>Reflection coefficient: absolute value of the reflection coefficient</i></p> <p><i>Uncertainty: expanded measurement uncertainty (k=2) for the reflection coefficients</i></p>
---	---

Table 6-5 Measurement file *rf(NRP-Z21)102972* for checking reflection (NRP sensors, variant 2)

<pre>[SENSOR-MEAS-DATA-FILE] CalDataType = REFLECTION_DATA DeviceList = "VNA, HP, 8510, 8430F9241, 199710A4435, 1998-05" "..." DataBlockEnd TestEngineer = "Peter Schmidt" Humidity = "40 to 60" // % r.H. Temperature = "20 to 25" // °C SerialNo = "102972" StockNo = "1081.2305.02" SensorType = "NRP-Z21" Date = "2004-05-12" DataPoints = 45 ValuesPerPoint = 4 Value = // Reflection coefficient of DUT //f/Hz Real part Imaginary part Uncertainty 5.000E+7 0.7350E-1 0.4808E-2 0.40E-2 1.000E+8 0.1584E-2 0.2645E-1 0.40E-2 5.000E+8 0.2937E-2 0.9173E-2 0.40E-2 4.000E+10 0.1742E-2 0.3245E-1 1.20E-2 DataBlockEnd</pre>	<p><i>Designation as measurement file</i></p> <p><i>Designation as reflection data</i></p> <p><i>List of measuring devices; a separate line is to be provided for each component:</i></p> <p><i>"<designation>, <manufacturer>, <type>, <serial no.>, <certificate no.>, <calibration expiry date>"</i></p> <p><i>The list must be terminated with DataBlockEnd.</i></p> <p><i>Name of test engineer</i></p> <p><i>Rel. humidity in %</i></p> <p><i>Comment line</i></p> <p><i>Temperature range in °C</i></p> <p><i>Comment line</i></p> <p><i>Serial number</i></p> <p><i>Material number</i></p> <p><i>Type designation</i></p> <p><i>Calibration date (12 May 2004)</i></p> <p><i>Number of frequencies</i></p> <p><i>Number of values per measurement point</i></p> <p><i>Assignment of calibration values</i></p> <p><i>Comment line</i></p> <p><i>Comment line</i></p> <p><i>List of values, with columns separated by at least one space.</i></p> <p><i>The list must be terminated with DataBlockEnd.</i></p> <p><i>Uncertainty: expanded measurement uncertainty (k=2) for the reflection coefficients</i></p>
--	--

Table 6-6 Measurement file *rf(NRV-Z15)843275.034* for checking reflection (R&S® NRV and R&S® URV5 sensors)

<pre>[SENSOR-MEAS-DATA-FILE] CalDataType = REFLECTION_DATA DeviceList = "VNA, HP, 8510, 8430F9241, 199710A4435, 1998-05" "..." DataBlockEnd TestEngineer = "Peter Schmidt" Humidity = "40 to 60" // % r.H. Temperature = "20 to 25" // °C SerialNo = "843275/034" StockNo = "1081.2305.02" SensorType = "NRV-Z15" Date = "2004-05-12" DataPoints = 45 ValuesPerPoint = 3 Value = // Reflection coefficient of DUT //f/Hz Magnitude Uncertainty 5.000E+7 0.8783E-2 0.40E-2 1.000E+8 0.8820E-2 0.40E-2 5.000E+8 0.9124E-2 0.40E-2 4.000E+10 8.7455E-2 1.20E-2 DataBlockEnd</pre>	<p><i>Designation as measurement file</i></p> <p><i>Designation as reflection data</i></p> <p><i>List of measuring devices; a separate line is to be provided for each component:</i></p> <p><i>"<designation>, <manufacturer>, <type>, <serial no.>, <certificate no.>, <calibration expiry date>"</i></p> <p><i>The list must be terminated with DataBlockEnd.</i></p> <p><i>Name of test engineer</i></p> <p><i>Rel. humidity in %</i></p> <p><i>Comment line</i></p> <p><i>Temperature range in °C</i></p> <p><i>Comment line</i></p> <p><i>Serial number</i></p> <p><i>Material number</i></p> <p><i>Type designation</i></p> <p><i>Calibration date (12 May 2004)</i></p> <p><i>Number of frequencies</i></p> <p><i>Number of values per measurement point</i></p> <p><i>Assignment of calibration values</i></p> <p><i>Comment line</i></p> <p><i>Comment line</i></p> <p><i>List of values, with columns separated by at least one space.</i></p> <p><i>The list must be terminated with DataBlockEnd.</i></p> <p><i>Uncertainty: expanded measurement uncertainty (k=2) for the reflection coefficients</i></p>
---	--

S-parameter file for sensors with attenuators

The R&S®NRP-Z22/-Z23/-Z24/-Z92 power sensors each contain two calibration data sets in the sensor's data memory. The first data set characterizes the power sensor and the second the attenuator in the form of all four S-parameters. The data for the attenuator can also be refreshed by providing **R&S®Recal+** with a file with current measurement data.

Table 6-7 gives an example of the structure of a file of this type in "RF" format for a power sensor of type R&S®NRP-Z22. Besides general information, this file contains a complete set of complex S-parameters for the attenuator. The S-parameters must be provided exclusively in linear notation, and for the measurement uncertainties a distinction is made between the reflection and transmission parameters. For the reflection coefficients s_{11} and s_{22} , the absolute uncertainties are necessary, while for the transmission coefficients s_{12} and s_{21} the relative uncertainties (in dB) are necessary. The uncertainties must be expanded by the factor $k = 2$ and refer in each case to the magnitudes.

The measurement frequencies in the calibration data set for an attenuator are generally more tightly spaced than the calibration frequencies of the power sensor. This is due in particular to the fact that the complex reflection coefficients of the power attenuators change faster vs. frequency than the reflection coefficients at the input of the power sensors, which is related to the longer line lengths inside the attenuators. If the spacing between the frequency points is too large, significant errors will arise in gamma correction between the power sensor and attenuator. In general, a frequency spacing of 50 MHz is adequate. It is best to select the frequency points in the existing calibration data set which can be read out with the **Create NRP View file** dialog and saved as an ASCII file in the `...\\recal+\\config32.dat` directory. The parameters for the attenuator can be found under the **S-Parameter Calibration Data** entry.

The **R&S®ZVX_RECAL** additional program does not support calibration of the attenuators since the possibility of significant measurement errors is much greater compared to power calibration. Accordingly, only experienced personnel should be allowed to perform calibration of attenuators using suitable measurement setups.

Table 6-7 Measurement data file SP(NRP-Z22.002)100042 for the S-parameters for the attenuator of an R&S®NRP-Z22 sensor

[SENSOR-MEAS-DATA-FILE]	Designation as measurement file
CalDataType = S_PARA_DATA	S-parameter measurement data
DeviceList = //<designation>, <manufacturer>, <type>, <serial no.>, <certificate no.>, <calibration expiry date> "VNA, HP, 8510, 8430F9241, 199710A4435, 1998-05" "..." DataBlockEnd	List of measuring devices; a separate line is to be provided for each component. The list must be terminated with DataBlockEnd.
TestEngineer = "Peter Schmidt"	Name of test engineer
Humidity = "40 to 60" // % r.H.	Rel. humidity in % Comment line
Temperature = "20 to 25" // °C	Temperature range in °C Comment line
SerialNo = "654321"	Component serial number
StockNo = "1234.5678.90"	Material number of component
ComponentType = "Weinschel 10 dB attenuator"	Component type designation
Date = "2001-10-21"	Calibration date
CalibrationLab = "R & S Messgerätebau Memmingen"	Calibration location
Family = ALL	Not a member of any specific sensor family
DataPoints = 360	Number of measurement frequencies
ValuesPerPoint = 13	Number of columns per frequency point
ComplexData = TRUE	Indicates that the measurement values are real and imaginary components of a complex value
Value = //f/Hz re_s11 im_s11 unc_s11 re_s12 im_s12 unc_s12 re_s21 im_s21 unc_s21 re_s22 im_s22 unc_s22 5.0E7 0.88E-2 0.40E-2 0.005 3.161E-1 0.240E-4 0.04 3.180E-1 0.861E-4 0.04 0.12E-1 0.11E-3 0.005 18.0E9 0.88E-1 0.22E-1 0.010 0.111E-2 2.462E-1 0.07 0.263E-2 2.501E-1 0.07 0.72E-1 0.41E-1 0.010 DataBlockEnd	Assignment of calibration values Comment line (no line break!) List of values, one line per measurement frequency, with columns separated by at least one space. The list must be terminated with DataBlockEnd.

Linearity

Linearity calibration of the R&S®NRV-Z6 and R&S®NRV-Z15 sensors is not possible with the R&S®NRVC since the 50 MHz frequency that is used is too low for these sensors. Instead, the measurements must be performed at 500 MHz, for example using the measurement setup shown in Fig. 6-13.

The R&S®NRV-Z1 or R&S®NRV-Z4 sensor which is used as a reference should have been linearized immediately beforehand using the calibration kit under the same ambient conditions and remain connected to the R&S®NRVD channel on which it was linearized. The harmonic ratio of the filtered generator signal should be at least 70 dB. Since the R&S®NRV-Z6 and R&S®NRV-Z15 themselves generate harmonics outside the square law region, the two attenuators must be used to provide decoupling. The precise attenuation values are not critical. The measured values are transferred in a file as shown in Table 6-8. This file contains the power value pairs at the reference sensor and at the DUT as well as general information. The size of the various power steps can be found under the header `linLevel` in the configuration file for the DUT (Fig. 6-14).

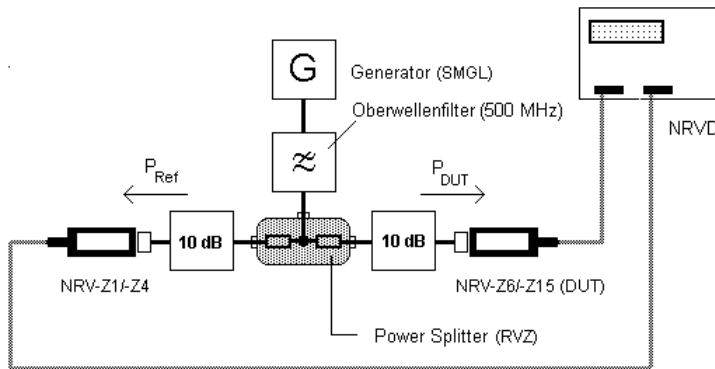

Fig. 6-13 Measurement setup for linearity calibration of the R&S®NRV-Z6 and R&S®NRV-Z15

DUT filter setting	→	...
		<code>linFilter = 7</code>
		...
Power steps (±0.5 dB)	→	<code>linLevel =</code>
		1.00E-006
		1.58E-006
		...
		...
		2.51E-2
		<code>DataBlockEnd</code>
		...
Power (±0.5 dB) at the reference point	→	<code>freqLevel = 1.0E-6</code>
		...

Fig. 6-14 Extract from configuration file `nrv-z15.002` (linearity)

In addition to each pair of values, the measurement file contains the expanded ($k=2$) measurement uncertainty U_{lin} in dB as the third quantity. Essentially, this is the expanded uncertainty $U_{\text{ref,lin}}$ of the reference sensor for ratio measurement plus a component for the R&S[®]NRVD:

$$U_{\text{lin}} = 2 \cdot \sqrt{\left(\frac{U_{\text{ref,lin}}}{2}\right)^2 + 3 \cdot u_{\text{NRVD},1}^2}$$

If a newly calibrated R&S[®]NRV-Z1 or R&S[®]NRV-Z4 power sensor is used as a reference, $U_{\text{ref,lin}}$ can be taken from the linearity calibration report. The following applies to the R&S[®]NRVD's component:

$$u_{\text{NRVD},1} = 0.0039 \text{ dB}$$

Enter the ratio of the power measured by the DUT to the reference power at the reference point (**freqLevel**) under **RefValue**.

Table 6-8 Measurement file *In(NRP-Z11.002)900123* for checking the linearity

<pre>[SENSOR-MEAS-DATA-FILE] CalDataType = LIN_RESPONSE Family = NRP DeviceList = "Power Sensor, R&S, NRV-Z1, 856345/011, 199A5, 1998-05" "Power Meter, R&S, NRVD, 845123/018, 567B221, 1999-10" "..." DataBlockEnd TestEngineer = "Peter Schmidt" Humidity = "40 to 60" // % r.H. Temperature = "20 to 25" // °C SerialNo = "900123" StockNo = "1138.3004.02" SensorType = "NRP-Z11" CalibrationLab = "SE2 Service Dept" Date = "2004-05-12" RefValue = 1.0024 RefUnit = -1 Test Frequency = 500.0E6 DataPoints = 24 ValuesPerPoint = 3 ValueUnit = W Value = // P_ref/W P_DUT/W uncertainty U_lin/dB 9.95123E-7 9.9751E-7 2.50E-2 1.57230E-6 1.5761E-6 2.50E-2 2.46220E-2 2.4631E-2 2.50E-2 DataBlockEnd SubstrateTemperature = 0.300000000E+3</pre>	<p><i>Designation as measurement file</i></p> <p><i>Designation as linearity data</i></p> <p><i>NRP (also valid for R&S®FSH) or NRV (also valid for R&S®URV5)</i></p> <p><i>List of measuring devices; a separate line is to be provided for each component:</i></p> <p><i>"<designation>, <manufacturer>, <type>, <serial no.>, <certificate no.>, <calibration expiry date>,"</i></p> <p><i>The list must be terminated with DataBlockEnd.</i></p> <p><i>Name of test engineer</i></p> <p><i>Rel. humidity in %</i></p> <p><i>Comment line</i></p> <p><i>Temperature range in °C</i></p> <p><i>Comment line</i></p> <p><i>Serial number</i></p> <p><i>Material number</i></p> <p><i>Type designation</i></p> <p><i>Name of Calibration Lab</i></p> <p><i>Calibration date (12 May 2004)</i></p> <p><i>P_{DUT} / P_{ref} for the reference point</i></p> <p><i>Reference value code</i></p> <p><i>Measurement frequency</i></p> <p><i>Number of frequencies</i></p> <p><i>Number of values per measurement point</i></p> <p><i>Unit of Value, V for sensors which are marked as VoltageSensor in the config file</i></p> <p><i>Assignment of calibration values</i></p> <p><i>Comment line</i></p> <p><i>List of values, columns separated by at least one space.</i></p> <p><i>Uncertainty U_{lin}/dB: expanded measurement uncertainty (k=2) in dB for power ratio measurements</i></p> <p><i>The list must be terminated with DataBlockEnd.</i></p> <p><i>Only NRP and FSH, fixed value.</i></p>
--	--

Absolute Accuracy

Calibration of the absolute accuracy can also be performed on a separate power calibration measurement setup.

The measurement results are transferred to the calibration software in an ASCII file in accordance with Table 6-9 (R&S®NRV or R&S®URV5 sensors) or Table 6-10 (R&S®NRP and R&S®FSH sensors). In addition to general information, this file contains the measured power value pairs for the standard and the DUT at each frequency point. The measurement frequencies and the calibration power levels can be obtained from the DUT configuration file:

<p>Reference frequency index</p> <p>Measurement frequencies</p>	<p>→</p> <p>→</p>	<pre> ... FRQREF = 2 frequencyresponse= 50E6 , 1.0 100E6 , 1.0 500E6 , 1.0 40E9 , 1.0 DataBlockEnd ... freqLevel = 1.0E-6 freqFilter = 7 ... </pre>
<p>Meas. power (±1.0 dB)</p> <p>Filter setting</p>	<p>→</p> <p>→</p>	

Fig. 6-15 Extract from configuration file *nrv-z15.002* (absolute accuracy).

For every frequency point, the expanded (k=2) measurement uncertainty U_{abs} in dB must be stated as the fourth quantity in the measurement file. Essentially, this is the expanded (k=2) measurement uncertainty $U_{ref,abs}$ of the calibration system (including the mismatch uncertainty) plus a component for the base unit and the ambient temperature and, in the case of the R&S®NRV-Z6 and R&S®NRV-Z15 diode sensors, a component that takes the effect of harmonics into account:

$$U_{abs} = 2 \cdot \sqrt{\left(\frac{U_{ref,abs}}{2}\right)^2 + u_{NRVD,1}^2 + [\alpha_{T,DUT} (T - 296.15K)]^2 + u_{h,one}^2}$$

$$u_{NRVD,1} = 0.0039 \text{ dB}$$

$$\alpha_{T,DUT} = 0.0015 \text{ dB/K} \quad [\text{R \& S NRV - Z6/ - Z15}]$$

$$0.0005 \text{ dB/K} \quad [\text{R \& S NRV - Z52/ - Z55}]$$

T = Sensor temperature in K

$$\frac{u_{h,one}}{\text{dB}} = \sqrt{\frac{P_{DUT}}{4 \mu\text{W}}} \cdot 10^{\frac{S}{20 \text{dB}}}$$

P_{DUT} is the power at the DUT, S the harmonic ratio. At a measurement power of 1 μW and a harmonic ratio of 25 dB, for example, the uncertainty $u_{h,one} = 0.028 \text{ dB}$.

The default frequency defined for the sensor type in question must be entered as the reference frequency **RefValue**. This is the frequency that is accepted by the base unit when the frequency-response correction is turned off.

The default frequency can be found in the corresponding configuration file, where the index **FRQREF** indicates the corresponding value in the frequency table (index 0 = 1st measurement frequency). In the example above (FRQREF=2), RefValue=5E8 would have to be entered.

Table 6-9 Measurement file *fr(NRV-Z15.002)843275.034* for checking absolute accuracy

<pre>[SENSOR-MEAS-DATA-FILE] CalDataType = FREQ_RESPONSE Family = NRV DeviceList = "Power Sensor, HP, 8478B, 3318A2465, 199A5, 1998-05" "Power Meter, HP, 432A, 1234A10012, 199A6, 1999-10" "..." DataBlockEnd TestEngineer = "Peter Schmidt" Humidity = "40 to 60" // % r.H. Temperature = "20 to 25" // °C SerialNo = "843275/034" StockNo = "1081.2305.02" SensorType = "NRV-Z15" Date = "2004-05-12" FKF = TRUE RefValue = 500.00000E+6 RefUnit = Hz TestLevel = 1.000000000E-6 GammaCorrection = TRUE DataPoints = 45 ValuesPerPoint = 4 ValueUnit = W Value = // f/Hz Ref. pwr./W DUT pwr./W Uncertainty U_abs/dB 5.00000E7 1.0034E-6 9.9987E-7 1.44E-2 1.00000E8 1.0141E-6 1.0187E-6 1.46E-2 5.00000E8 1.0273E-6 1.0337E-6 1.51E-2 4.00000E10 9.0114E-7 8.8547E-7 2.88E-1 DataBlockEnd</pre>	<p><i>Designation as measurement file</i></p> <p><i>Designation as measurement data for absolute accuracy</i></p> <p><i>Also NRV for URV5 sensors</i></p> <p><i>List of measuring devices; a separate line is to be provided for each component:</i></p> <p><i>"<designation>, <manufacturer>, <type>, <serial no.>, <certificate no.>, <calibration expiry date>"</i></p> <p><i>The list must be terminated with DataBlockEnd.</i></p> <p><i>Name of test engineer</i></p> <p><i>Rel. humidity in %</i></p> <p><i>Comment line</i></p> <p><i>Temperature range in °C</i></p> <p><i>Comment line</i></p> <p><i>Serial number</i></p> <p><i>Material number</i></p> <p><i>Type designation</i></p> <p><i>Calibration date (12 May 2004)</i></p> <p><i>Measurement done with frequency correction turned on, should be always TRUE.</i></p> <p><i>Reference frequency</i></p> <p><i>Reference frequency unit</i></p> <p><i>Nominal level for Measurement</i></p> <p><i>Measurement with/without gamma correction</i></p> <p><i>Number of frequencies</i></p> <p><i>Number of values per measurement point</i></p> <p><i>Unit of Value and TestLevel, V for sensors which are marked Voltage-Sensor in the config file.</i></p> <p><i>Assignment of calibration values</i></p> <p><i>Comment line</i></p> <p><i>List of values, columns separated by at least one space.</i></p> <p><i>Uncertainty U_abs/dB: eX-panded uncertainty (k=2) for calibration of absolute accuracy.</i></p> <p><i>The list must be terminated with DataBlockEnd.</i></p>
---	--

Table 6-10 Measurement file *fr(NRP-Z11.002)900123* for checking absolute accuracy

<pre>[SENSOR-MEAS-DATA-FILE] CalDataType = FREQ_RESPONSE Family = NRP DeviceList = "Power Sensor, HP, 8478B, 3318A2465, 199A5, 1998-05" "Power Meter, HP, 432A, 1234A10012, 199A6, 1999-10" "..." DataBlockEnd TestEngineer = "Peter Schmidt" Humidity = "40 to 60" // % r.H. Temperature = "20 to 25" // °C SerialNo = "900123" StockNo = "1138.3004.02" SensorType = "NRP-Z11" Date = "2004-05-12" CalibrationLab = "SE2 Service Dept" FKF = TRUE RefValue = 500.00000E+6 RefUnit = Hz GammaCorrection = TRUE TestLevels = 10.00E-6 1.00E-3 1.00E-3 DataBlockEnd DataPoints = 45 ValuesPerPoint = 4 ValueUnit = W Value = // f/Hz Ch1_Ref_Pwr/W Ch1_DUT_Pwr/W Ch1_unc/dB ↳Ch2_Ref_Pwr/W Ch2_DUT_Pwr/W Ch2_unc/dB Ch3_Ref_Pwr/W ↳Ch3_DUT_Pwr/W Ch3_unc/dB 10.00000E+6 0.012600394E-3 0.012583287E-3 0.02949060 ↳1.26928072E-3 1.2674270E-3 0.0267329 1.269419463E-3 ↳1.268397333E-3 0.027131145 8.0000000E+9 0.0101924E-3 0.01018197E-3 0.04508305 ↳1.0275804E-3 1.02591166E-3 0.0363610 1.02847939E-3 ↳1.027831333E-3 0.036797888 DataBlockEnd SubstrateTemperature = 0.300000000E+3</pre>	<p><i>Designation as measurement file</i></p> <p><i>Designation as measurement data for absolute accuracy</i></p> <p><i>Also NRP for FSH sensors</i></p> <p><i>List of measuring devices; a separate line is to be provided for each component:</i></p> <p><i>"<designation>, <manufacturer>, <type>, <serial no.>, <certificate no.>, <calibration expiry date>"</i></p> <p><i>The list must be terminated with DataBlockEnd.</i></p> <p><i>Name of test engineer</i></p> <p><i>Rel. humidity in %</i></p> <p><i>Comment line</i></p> <p><i>Temperature range in °C</i></p> <p><i>Comment line</i></p> <p><i>Serial number</i></p> <p><i>Material number</i></p> <p><i>Type designation</i></p> <p><i>Calibration date (12 May 2004)</i></p> <p><i>Name of Calibration Lab</i></p> <p><i>Always TRUE for R&S®NRP sensors</i></p> <p><i>Reference frequency</i></p> <p><i>Reference frequency unit</i></p> <p><i>Measurement with/without gamma correction</i></p> <p><i>Nominal levels of Measurements for 3 path sensors</i></p> <p><i>For R&S®NRP-Z51:</i></p> <p><i>TestLevel = ... without DataBlockEnd</i></p> <p><i>Number of frequencies</i></p> <p><i>Number of values per meas. point</i></p> <p><i>Unit of Value and TestLevel (always W for R&S®NRP sensors).</i></p> <p><i>Assignment of calibration values</i></p> <p><i>Comment line, data must be given in this order</i></p> <p><i>List of values (here NRP), number of columns must be ValuesPerPoint, columns separated by at least one space.</i></p> <p><i>Uncertainty U_abs/dB: expanded uncertainty (k=2) for calibration of absolute accuracy.</i></p> <p><i>The list must be terminated with DataBlockEnd.</i></p> <p><i>Only for R&S®NRP and R&S®FSH, fixed value.</i></p>
--	--

Measurement Uncertainty

The measurement uncertainties for absolute accuracy and linearity specified in the calibration report are calculated individually for each sensor by the calibration software, based on the ISO Guide to the Expression of Uncertainty in Measurement*). The measurement uncertainty contributions of the different influence quantities are combined statistically. The calculated measurement uncertainty is the "expanded uncertainty" with an expansion factor of $k=2$. Assuming normal distribution of the values, the uncertainty range has a coverage probability of 95%.

The influence quantities relevant for calculating the measurement uncertainty are explained in the following, and the formulas for the associated relative standard uncertainties u_i are specified in dB. The expanded measurement uncertainty U is calculated based on the following equation:

$$\frac{U}{\text{dB}} = 2 \cdot \sqrt{\sum_i \left(\frac{u_i}{\text{dB}} \right)^2}$$

Calibration of Absolute Accuracy

The relevant influence quantities for the calibration are listed in Table 6-11 (R&S®NRP-Z/FSH-Z sensors) and Table 6-12 (R&S®NRV-Z / R&S®URV5-Z sensors). The individual influence quantities related to the measurement uncertainty for the power standards are presented separately for the R&S®NRPC power standards. The influence quantities are explained below in greater detail:

1. Measurement uncertainty of the power standard ①

R&S®NRPC calibration kit

This expresses the uncertainty of the power of the emanating wave at the test port. The influence quantities are shown in Table 6-13. During operation of an R&S®NRPC33 or R&S®NRPC40 with the 20 dB reference attenuator, the influence quantities in Table 6-14 must also be taken into account.

R&S®NRVC calibration kit

This expresses the uncertainty of the power of the emanating wave at the test port. The uncertainty is calculated by means of the R&S®NRVD firmware based on the ISO Guide and influence quantity numbers **20** to **26** in Table 6-15 are taken into account. To avoid rounding errors, the value read out from the R&S®NRVD with a resolution of 0.01 dB is increased by 0.005 dB prior to further processing in **R&S®Recal+**.

The expanded measurement uncertainty of the R&S®NRVC power standard can be manually displayed at any time by pressing the **DISP** key and selecting the **LEV+UNC** menu item on the R&S®NRVD base unit (e.g. **1.0045 mW 0.12 dB RSS**), or it can be read out with the corresponding remote control command. In both cases, the standing wave ratio (SWR) of the connected component (DUT or 20 dB reference attenuator) has to be transferred to the R&S®NRVD. During usage of the 20 dB reference attenuator, the influence quantities shown in Table 6-16 must also be taken into account.

*) ISO Guide to the Expression of Uncertainty in Measurement. First edition 1993, corrected and reprinted 1995, International Organization for Standardization, Geneva, Switzerland, ISBN: 92-67-10188-9, 1995.

Table 6-11 Influence quantities for calibration of absolute accuracy (R&S® NRP-Z and R&S® FSH-Z sensors)

Item no.	DUT ⇒ Calibration level / dBm ⇒ ↓ Influence quantity	Power sensor (therm.) R&S® NRP-Z5x	Power sensor (diode) R&S® ...		Power sensor (diode) R&S® ...
			NRP-Z11, -Z21 -Z31, -Z91 FSH -Z1, -Z18	NRP-Z211, -Z221 -Z81, -Z85 -Z86	NRP-Z22, -Z23 -Z24, -Z92
		0	-20 / 0	-10	-20/0*
1	Measurement uncertainty of power standard	•	•	•	•
2	Reproducibility of RF connection at test port to DUT	•	•	•	•
3	Influence of 2nd and 3rd harmonics		•	•	•
4	Ambient temperature (DUT)	•	•	•	•
5	Zero offset and display noise (DUT)	•	•	•	•
6	Measurement uncertainty of reference meas. path in DUT		•		•
7	Measurement uncertainty for DUT's attenuator				•

Table 6-12 Influence quantities for calibration of absolute accuracy (R&S® NRV-Z / R&S® URV5-Z sensors)

Item no.	DUT ⇒ Calibration level / dBm ⇒ ↓ Influence quantity	Power sensor (therm.) R&S® ...	Power sensor (diode) R&S® ...		Insertion unit R&S® ...		RF probe R&S® ...
		NRV-Z51 -Z52 -Z53 -Z54 -Z55	NRV-Z1 -Z4 -Z7 - Z31	NRV-Z2 -Z5 -Z8 -Z32 -Z33	URV5-Z2	URV5-Z4	URV5-Z7
		0 / +10	-30 / -20	-10 / 0/+10	-30	-10	-30
1	Measurement uncertainty of power standard	•		•	•	•	•
1-A	Measurement uncertainty of power standard with reference attenuator (2)		•		•		•
2	Reproducibility of RF connection at test port	•	•	•	•	•	•
3	Influence of 2nd and 3rd harmonics		•	•	•	•	•
4	Ambient temperature (DUT)	•	•	•	•	•	•
5	Zero offset and display noise (DUT)	•	•	•	•	•	•
8	Mismatch of termination				•	•	
9	Measurement uncertainty of base unit for absolute power measurements (DUT)	•	•	•	•	•	•

* On sensor; without attenuator.

Table 6-13 Influence quantities for the measurement uncertainty of the R&S®NRPC power standard ①.

Item no.	Influence quantity
10	Measurement uncertainty by reference to internal reference circuit
11	Calibration uncertainty
12	Mismatch uncertainty at test port

13	Linearity uncertainty
14	Ambient temperature
15	Zero offset and display noise

Table 6-14 Additional influence quantities for the measurement uncertainty of the R&S®NRPC power standard with 20 dB reference attenuator ②.

Item no.	Influence quantity
16	Reproducibility of RF connection at output of reference attenuator
17	Calibration uncertainty of 20 dB reference attenuator
18	Mismatch uncertainty between DUT and reference attenuator

Table 6-15 Influence quantities for the measurement uncertainty of the R&S®NRVC power standard ①.

Item no.	Influence quantity
19	Measurement uncertainty in case of verification with DC voltage
20	Calibration uncertainty
21	Mismatch uncertainty at test port
22	Linearity uncertainty
23	Ambient temperature

24	Zero offset and display noise
25	Quantization noise
26	Measurement uncertainty of base unit after DC calibration of power standard

Table 6-16 Additional influence quantities for the measurement uncertainty of the R&S®NRVC power standard with 20 dB reference attenuator ②.

Item no.	Influence quantity
27	Calibration uncertainty of 20 dB reference attenuator
28	Mismatch uncertainty between DUT and reference attenuator

29	Reproducibility of RF connection at output of reference attenuator
----	--

2. Reproducibility of RF connection at test port of power standard ^①

For the standard uncertainty u_r of the random attenuation deviation from the average value, the following equation applies:

$$\frac{u_r}{\text{dB}} = \frac{u_{r1}}{\sqrt{N}}$$

The value N is the number of measurement cycles (1, 2, 3, 4), and u_{r1} is a specified value *) for N connectors (made of stainless steel, 10000 plugging operations). The spread for the other connectors was estimated on an empirical basis from statistical analyses.

Table 6-17 Spread (1σ) of insertion loss of connectors of type N-50Ω

Frequency	0 to 8.0 GHz	> 8.0 GHz to 12.4 GHz	> 12.4 GHz to 18 GHz
u_{r1} / dB	0.0045	0.0070	0.0105

Table 6-18 Spread (1σ) of insertion loss of connectors of type PC 3.5 mm, PC 2.92 mm and PC 2.4 mm

Frequency	0 to 2.0 GHz	> 2.0 GHz to 8.0 GHz	> 8 GHz to 13 GHz	> 13 GHz to 26.5 GHz	> 26.5 GHz to 40 GHz	> 40 GHz to 50 GHz
u_{r1} / dB	0.003	0.005	0.0070	0.009	0.011	0.013

3. Influence of 2nd and 3rd harmonics

Harmonics of the test signal can influence the measurement accuracy of power or voltage sensors using diode rectifiers. Compared to a thermal power meter (as used in the power standard), a power level that is slightly too high or too low is measured depending on the phase of the second and third harmonics with reference to the fundamental. Based on the maximum measurement errors*) determined empirically and by applying a u distribution as a function of phase angle, a formulation for the standard uncertainty u_h is obtained. This formulation depends on the actual configuration of the detector and is described below for the various types of sensors.

R&S® NRP-Z11/-Z21/-Z22/-Z23/-Z24/-Z31/-Z91/-Z92 and R&S® FSH-Z1/-Z18 3-path sensors

These sensors are multi-path devices with a full-wave rectifier. The uncertainty must be determined separately for each measurement path. For the standard uncertainty u_h , the following formulation is applied:

$$\frac{u_h}{\text{dB}} = \frac{P_{\text{DUT}}}{P_{\text{ref}} \cdot 10^{2(k-1)}} \cdot 10^{-\frac{S+30 \text{ dB}}{20 \text{ dB}}}$$

where

- k Measurement path (1, 2, 3)
- P_{DUT} Calibration power
- S Ratio of the generator's third harmonic (see configuration files)
- P_{ref} 9 μW

*) D. Bergfried, H. Fischer: Insertion-Loss Repeatability Versus Life of Some Coaxial Connectors. IEEE Trans. on Instrumentation and Measurement, Vol. IM-19, No. 4, pp. 349-353 (Table I), November 1970.

*) Voltage and Power Measurements – Fundamentals, Definitions, Products. ROHDE & SCHWARZ publication PD 757.0835.12 (Fig. 28), 1995.

R&S®NRP-Z211/-Z221 2-path sensors

The R&S®NRP- Z211/-Z221 devices are two-path sensors with a full-wave rectifier. The uncertainty must be determined separately for each measurement path. For the standard uncertainty u_h , the following formulation is applied:

$$\frac{u_h}{\text{dB}} = \frac{P_{\text{DUT}}}{P_{\text{ref}} \cdot 500^{k-1}} \cdot 10^{-\frac{S+30\text{dB}}{20\text{dB}}}$$

where

k	Measurement path (1,2)
P_{DUT}	Calibration power
S	Ratio of the generator's third harmonic (see configuration files)
P_{ref}	72 μW

R&S®NRP-Z81, -Z85, -Z86 wideband power sensors

The R&S®NRP-Z81, -Z85, -Z86 devices are wideband power sensors with a full-wave rectifier. For the standard uncertainty u_h , the following formulation is applied:

$$\frac{u_h}{\text{dB}} = \frac{2.17}{1 + \frac{P_{\text{ref}}}{P_{\text{DUT}}}} \cdot 10^{-\frac{S}{20\text{dB}}}$$

where

P_{ref}	300 μW
P_{DUT}	Calibration power
S	Ratio of the generator's third harmonic (see configuration files)

For the wideband power sensors, an additional error must be taken into account besides the influence of the harmonics produced by the generator. This is due to the fact that wideband power sensors generate their own disruptive harmonics. These harmonics are reflected partially at the power standard's test port and thus cause a change in the input signal. The share of the reflected harmonic is determined by the reflection at the test port at the frequency of the harmonic. In the frequency range up to 4 GHz, the influence is dominated by the third harmonic. At higher frequencies, the influence of the second harmonic predominates.

Frequency \leq 4 GHz

$$\frac{u_{hS}}{\text{dB}} = 0.062 \cdot |\Gamma_S(3 \cdot f)| \frac{P_{\text{DUT}}^{1.5}}{5.7 \cdot 10^{-4} \text{ W} + P_{\text{DUT}}^{1.5}}$$

Frequency $>$ 4 GHz

$$\frac{u_{hS}}{\text{dB}} = 0.037 \cdot |\Gamma_S(2 \cdot f)| \frac{P_{\text{DUT}}^{1.5}}{3.5 \cdot 10^{-4} \text{ W} + P_{\text{DUT}}^{1.5}}$$

$$|\Gamma_S(v)| = 0.35 \text{ für } v \leq 1.05 \cdot f_{\text{up}}$$

$$|\Gamma_S(v)| = 0.90 \text{ für } v > 1.05 \cdot f_{\text{up}}$$

where

P_{DUT}	Calibration power in W
------------------	------------------------

$|Γ_S(ν)|$ Assumption for the magnitude of the reflection coefficient at the test port of the power standard at the frequency of the harmonic

f_{up} Upper frequency limit of the power standard (see Table 1-1), e.g.: 40 GHz for an R&S®NRPC40. For measurement frequencies below 4 GHz, set $ν$ to triple the value of the measurement frequency, and above this set it to double the value

R&S®NRV and R&S®URV5 sensors

These sensors have only one measurement path, but a distinction must be made on the basis of the type of rectifier (see Table 6-19). For the standard uncertainty $u_{h,one}$ using a half-wave rectifier, the following equation applies:

$$\frac{u_{h,one}}{dB} = \sqrt{\frac{P_{DUT}}{P_{ref}}} \cdot 10^{-\frac{S}{20dB}}$$

For the standard uncertainty $u_{h,two}$ using a full-wave rectifier, the following equation applies:

$$\frac{u_{h,two}}{dB} = \frac{P_{DUT}}{P_{ref}} \cdot 10^{-\frac{S+30dB}{20dB}}$$

It is assumed that the measurement errors occurring for a half-wave rectifier are caused mainly by the second harmonic and for a full-wave rectifier mainly by the third harmonic.

S is the harmonic ratio for the generator used in dB (see configuration files), P_{DUT} is the calibration power for the DUT in W and P_{ref} is a reference power in W specified for the corresponding sensor.

Table 6-19 Characteristic values for the R&S®NRV-Z and R&S®URV5-Z diode sensors

Sensor type ⇒ R&S®...	NRV-Z1, -Z6, -Z7, -Z15	NRV-Z2, -Z8	NRV-Z4, -Z31	NRV-Z5, -Z32	NRV-Z33	URV5-Z2, -Z7	URV5-Z4
P_{ref}	4 μW	400 μW	1 μW	100 μW	1 mW	1 μW	100 μW
Rectifier	Half-wave	Half-wave	Full-wave	Full-wave	Full-wave	Full-wave	Full-wave

4. Ambient temperature (DUT)

All sensors except R&S®NRP-Z81/-Z85/-Z86 wideband power sensors

Since the calibration uncertainty stated in the calibration report is valid for an ambient temperature of 23 °C (296.15 K), an additional measurement uncertainty has to be taken into account for the DUT at other calibration temperatures. For a standard uncertainty $u_{T,abs}$, the following equation applies:

$$\frac{u_{T,abs}}{dB} = \alpha_{T,DUT} (T - 296.15K)$$

T is the ambient temperature (in Kelvin) measured by the R&S®NRVD or R&S®NPR2 in the power standard and $\alpha_{T,DUT}$ is a standard deviation of the remaining temperature coefficient for the DUT after internal temperature correction, valid for the range from 20 °C to 25 °C. For diode sensors, a value of 0.0015 dB/K is generally assumed, and for thermal sensors, a value of 0.0005 dB/K.

R&S®NRP-Z81/-Z85/-Z86 wideband power sensors

The ambient temperature has only a slight impact with these sensors since internal correction is performed at each operating temperature. In the end, there is only a small influence in the sensor due to the temperature measurement. Independent of the frequency, level and temperature, a standard uncertainty is assumed for this influence as follows:

$$\frac{u_{T,abs}}{dB} = 2 \cdot 10^{-3}$$

5. Zero offset and display noise (DUT)**R&S®NRP-Z11/-Z21/-Z22/-Z23/-Z24/-Z31/-Z91/-Z92 and R&S®FSH-Z1/-Z18 3-path sensors**

In the three-path sensors, the influence of the zero point and noise is taken into account with the following equation:

$$\frac{u_{z+n,DUT}}{dB} = \frac{2.172}{\sqrt{N}} \cdot \sqrt{\left(\frac{P_{n(DUT),0}}{P_{DUT} \cdot 10^{-2(k-1)}}\right)^2 \cdot \frac{1s}{2T_A M} + \left(\frac{P_{z(DUT),0}}{P_{DUT} \cdot 10^{-2(k-1)}}\right)^2}$$

N	Number of measurement cycles (1, 2, 3, 4)
k	Measurement path (1, 2, 3)
$2T_A$	Width of measurement window (generally 2×20 ms)
M	Averaging factor (2, 4, 8, etc.)
P_{DUT}	Calibration power
$P_{n(DUT),0}$	2- σ -display noise for path 1 at a measurement time of 1 s (typ. 128 pW)
$P_{z(DUT),0}$	Zero offset for path 1 at an integration time of 4 s (typ. 64 pW)

R&S®NRP-Z211/-Z221 2-path sensors

In the R&S®NRP-Z211/-Z221 two-path diode sensors, the influence of the zero point and noise is taken into account with the following equation:

$$\frac{u_{z+n,DUT}}{dB} = \frac{2.172}{\sqrt{N}} \cdot 500^{k-1} \sqrt{\left(\frac{P_{n(DUT)}}{P_{DUT}}\right)^2 \cdot \frac{1s}{2T_A M} + \left(\frac{P_{z(DUT)}}{P_{DUT}}\right)^2}$$

N	Number of measurement cycles (1, 2, 3, 4)
k	Measurement path (1, 2)
$2T_A$	Width of measurement window (generally 2 × 20 ms)
M	Averaging factor (2, 4, 8, etc.)
P_{DUT}	Calibration power
$P_{n(DUT)}$	2- σ -display noise at a measurement time of 1 s (typ. 560 pW)
$P_{z(DUT)}$	Zero offset at an integration time of 4 s (typ. 560 pW)

R&S®NRP-Z51/-Z52/-Z55/-Z56 thermal sensors and R&S®NRP-Z81/-Z85/-Z86 wideband sensors
 In the thermal sensors and wideband sensors, the influence of the zero point and noise is taken into account with the following equation:

$$\frac{u_{z+n,DUT}}{dB} = \frac{2.172}{\sqrt{N}} \cdot \sqrt{\left(\frac{P_{n(DUT)}}{P_{DUT}}\right)^2 \cdot \frac{1s}{2T_A M} + \left(\frac{P_{z(DUT)}}{P_{DUT}}\right)^2}$$

- N Number of measurement cycles (1, 2, 3, 4)
- 2T_A Width of measurement window
- M Averaging factor (2, 4, 8, etc.)
- P_{DUT} Calibration power
- P_{n(DUT)} 2-σ-display noise at a measurement time of 1 s (Table 6-20)
- P_{z(DUT)} Zero offset (Table 6-20)

Table 6-20 Display noise and zero offset

Sensor type ⇒ R&S® ...	R&S®NRP-					
	Z51/Z55 (Var .02)	Z52 (Var .18)	Z52 (Var .02)	Z51/Z55 (Var .03)	Z56	Z81/Z85/Z86
Integration time for zeroing	4 s	4 s	10 s	10 s	10 s	4 s
P _{n(DUT)}	80 nW	80 nW	60 nW	60 nW	60 nW	0.74 nW
P _{z(DUT)}	60 nW	60 nW	25 nW	25 nW	25 nW	0.46 nW

R&S®NRV and R&S®URV5 sensors

To simplify calculation, the same equation for standard uncertainty is applied for all sensors:

$$\frac{u_{z+n,DUT}}{dB} = \frac{0.005}{\sqrt{N}}$$

This equation was derived for R&S®NRV-Z54 sensors. For all other sensor types, the uncertainties that are calculated using this equation are considerably higher than the values actually to be expected.

6. Measurement uncertainty of the reference path in the DUT

The R&S®NRP-Z11/-Z21/-Z22/-Z23/-Z24/-Z91/-Z31/Z41/Z61/-Z92 and R&S®FSH-Z1/-Z18 sensors each contain three measurement paths with different sensitivity which must be calibrated individually. The less sensitive measurement paths 2 and 3 can be adjusted at 0 dBm, while the more sensitive measurement path 1 requires a calibration level of -20 dBm.

Since the R&S®NRPC and R&S®NRVC power standards cannot provide this level at the degree of accuracy required, the DUT itself is used as a reference, and specifically the center measurement path (2). The **R&S®Recal+** software ensures that this measurement path was itself adjusted (at 0 dBm) prior to a calibration at -20 dBm. In contrast to the method with a 20 dB attenuator connected (see R&S®NRV-Z1 sensor, for example), a somewhat lower total measurement uncertainty and outstanding linearity are achieved for switchover from one measurement path to another.

The total measurement uncertainty is larger by the value of the influence of the linearity of measurement path 2. For this influence quantity, a standard uncertainty is applied as follows:

$$\frac{u_{\text{lin_ref}}}{\text{dB}} = \sqrt{1.0 \cdot 10^{-5} \cdot \left(\frac{f}{f_u}\right)^{-4} + 1.7 \cdot 10^{-6} + 6.8 \cdot 10^{-6} \cdot \left(\frac{f}{\text{GHz}}\right) + 1.0 \cdot 10^{-10} \cdot \left(\frac{f}{\text{GHz}}\right)^4}$$

f_u : 9 kHz for R&S®NRP-Z91/-Z92,
10 MHz for all other multi-path sensors excluded NRP-Z41/-Z61

For the R&S®NRP-Z41/-Z61 it follows:

$$\frac{u_{\text{lin_ref}}}{\text{dB}} = \sqrt{1.63 \cdot 10^{-4} + 17 \cdot 10^{-6} \cdot \left(\frac{f}{\text{GHz}}\right) + 7.3 \cdot 10^{-8} \cdot \left(\frac{f}{\text{GHz}}\right)^2}$$

7. Measurement uncertainty for connected attenuator

In the case of the R&S®NRP-Z22/-Z23/-Z24/-Z92 sensors, the calibration data is stored separately for the power sensor and the attenuator so that measurements can also be performed without the attenuator. As a result, the power sensor and the attenuator must also be calibrated separately.

The uncertainties for adjustment of the attenuator are to be transferred in the measurement file for the attenuator (see section **Measurements on a Separate Measurement Setup**). These uncertainties are stored in this form in the sensor data memory and are also output in the test report for the attenuator. They are not added to the uncertainties for the sensor.

8. Mismatch of termination ^⑥

In case of a mismatch (reflection coefficient Γ_{TERM}), the termination produces standing waves with an $SWR \approx 1 + 2 |\Gamma_{\text{TERM}}|$. This causes a voltage that is slightly too high or too low to be measured in the R&S®URV5-Z2 and R&S®URV5-Z4 insertion units depending on the frequency or phase angle of Γ_{TERM} (***)). Based on a u distribution of the measurement errors vs. the phase angle as well as a rectangular distribution of $|\Gamma_{\text{TERM}}|$ between the specified maximum value $|\Gamma_{\text{TERM}}|_{\text{max}}$ (see data sheet / technical information for the R&S®NRVC) and a half multiple of this value, the following value is applied for the standard uncertainty:

$$\frac{u_{\text{TERM}}}{\text{dB}} = 20 \cdot \lg \left(1 + \frac{0.75 \cdot |\Gamma_{\text{TERM}}|_{\text{max}}}{\sqrt{2}} \right)$$

9. Measurement uncertainty of the R&S®NRVD base unit for absolute power measurements (DUT)

To account for the influence of the base unit, the following standard uncertainty $u_{\text{NRVD},1}$ is applied:

$$\frac{u_{\text{NRVD},1}}{\text{dB}} = 0.0039$$

This value has been proven to be adequate provided that the R&S®NRVD is calibrated once a year and the operating temperature range is 20 °C to 25 °C.

***) Voltage and Power Measurements – Fundamentals, Definitions, Products. ROHDE & SCHWARZ publication PD 757.0835.12 (Fig. 12/13), 1995.

Influence Quantities for the Measurement Uncertainty of the R&S® NRPC Power Standard ①

10. Measurement uncertainty during verification with DC voltage

As discussed in the section Built-In Self-Test of the Power Standard on page 66, an in-circuit test is performed prior to each calibration of absolute accuracy using an internal reference circuit. As the remaining measurement uncertainty following this correction, a standard uncertainty is obtained as follows:

$$\frac{u_{\text{DC,NRPC}}}{\text{dB}} = 2.2 \cdot 10^{-3}$$

11. Calibration uncertainty for the power standard

This factor is the uncertainty for the ratio between the power available at the test port in the case of matching and the power indicated by the R&S® NRP2 at approximately 1 mW.

The calibration uncertainty can be found in the specification for the R&S® NRPC (data sheet, **Measurement uncertainty**). It is valid assuming prior successful verification of the R&S® NRPC using an R&S® NRPC-B1 verification set (Chapter 4, **Verification**).

12. Mismatch uncertainty at the test port of the power standard

Mismatching can cause the power fed to the DUT to be larger or smaller than the value that would occur in the case of ideal matching. Different measurement uncertainty contributions are obtained depending on the correction of this influence.

Without gamma correction

If the mismatch is not corrected because no complex reflection coefficients are available, for example, the following standard uncertainty is obtained assuming a u distribution:

$$\frac{u_{\text{m,NRPC}}}{\text{dB}} = 6.142 \cdot |\Gamma_{\text{eq}}| \cdot |\Gamma_{\text{load}}|$$

$|\Gamma_{\text{eq}}|$ is the magnitude of the equivalent reflection coefficient at the test port and $|\Gamma_{\text{load}}|$ is the magnitude of the reflection coefficient of the connected load, i.e. $|\Gamma_{\text{load}}| = |\Gamma_{\text{DUT}}|$.

With gamma correction

If complex matching measured values are present for the DUT, the measurement errors caused by mismatching can largely be corrected (gamma correction).

The remaining uncertainty is then very small and can be calculated with the following equation:

$$\frac{u_{\text{m}(\Gamma),\text{NRPC}}}{\text{dB}} = 8.686 \cdot \sqrt{|\Gamma_{\text{eq}}|^2 u_{\Gamma_{\text{load}}}^2 + |\Gamma_{\text{load}}|^2 u_{\Gamma_{\text{eq}}}^2 + u_{\Gamma_{\text{load}}}^2 u_{\Gamma_{\text{eq}}}^2}$$

In the above equation, $u_{\Gamma_{\text{eq}}}$ and $u_{\Gamma_{\text{load}}}$ represent a standard uncertainty for the parameters $|\Gamma_{\text{eq}}|$ and $|\Gamma_{\text{load}}| = |\Gamma_{\text{DUT}}|$.

13. Linearity uncertainty of the power standard

The nominal calibration power of the standard is 0 dBm. For power levels within ± 3 dB of 0 dBm, the influence of the power standard's nonlinearity is contained in the power standard's calibration uncertainty (number **11**). Outside of this range, the following standard uncertainty applies:

$$\frac{u_{\text{lin,NRPC}}}{\text{dB}} = 7 \cdot 10^{-3}$$

14. Influence of the ambient temperature on the power standard

For the power standard, the temperature influence is contained in the calibration uncertainty (number **11**) as long as the temperature is in the range from 20 °C to 25 °C. Outside of this range, the following standard uncertainty applies:

$$\frac{u_{\text{T,abs}}}{\text{dB}} = 0.0005 \text{ dB/K} \cdot (T - 296.15\text{K})$$

15. Zero offset and display noise of the power standard

Analogously to item **5**, the following formulation is used for the standard uncertainty:

$$\frac{u_{\text{z+n,NRPC}}}{\text{dB}} = \frac{2.172}{\sqrt{N}} \cdot \sqrt{\left(\frac{P_{\text{n(NRPC)}}}{P_{\text{cal}}}\right)^2 \cdot \frac{1 \text{ s}}{2T_A M} + \left(\frac{P_{\text{z(NRPC)}}}{P_{\text{cal}}}\right)^2}$$

N	Number of measurement cycles (1, 2, 3, 4)
$2T_A$	Width of measurement window
M	Averaging factor (2, 4, 8, etc.)
$P_{\text{n(NRPC)}}$	2- σ -display noise at a measurement time of 1 s (typ. 60 nW)
$P_{\text{z(NRPC)}}$	Zero offset at an integration time of 10 s (typ. 25 nW)
P_{cal}	Power at the test port

Additional Influence Quantities for the Measurement Uncertainty of the R&S[®] NRPC Power Standard with 20 dB Reference Attenuator ②

16. Reproducibility of RF connection at output of reference attenuator

Calculation is performed as described under 2.

17. Calibration uncertainty with 20 dB reference attenuator

After activating the S-parameters in the power standard, the attenuation of the 20 dB reference attenuator is automatically taken into account. The mismatch interaction on the common interface between the power standard and the reference attenuator is taken into account in the attenuation correction. The calibration uncertainty of the power standard with the 20 dB attenuator can be found in the specification for the R&S[®] NRPC (data sheet, **Measurement uncertainty**).

18. Mismatch uncertainty between DUT and reference attenuator

Calculation is performed as described under 12. Here, $|\Gamma_{\text{eq}}|$ and $|\Gamma_{\text{DUT}}|$ are the magnitudes of the reflection coefficients of the reference attenuator and DUT on the common interface.

Influence Quantities for the Measurement Uncertainty of the R&S[®] NRVC Power Standard ①

19. Measurement uncertainty during verification with DC voltage

Because of their accuracy, the digital voltmeter used as a reference for DC voltage measurements and the 50 \square resistor contained in the DC termination both influence the measurement uncertainty during **DC voltage tests**. Due to the correction factors K_{NRVC} and K_{ATT} , they also influence the measurement uncertainty for all subsequent calibrations of absolute accuracy.

Assuming a tolerance of $\pm 0.01\%$ for the digital voltmeter, a display noise of ± 2 **digits** for a 5-digit display (0.22500 V or 0.022500 V), a tolerance of $\pm 0.01\%$ for the 50 Ohm resistor and rectangular distribution of all measurement errors, the standard uncertainty for these influence quantities is as follows:

$$\frac{u_{\text{DC,NRVC}}}{\text{dB}} = 6 \cdot 10^{-4}$$

20. Calibration uncertainty for the power standard

This factor is the uncertainty for the ratio between the power available at the test port in the case of matching and the power indicated by the R&S[®] NRVC at approximately 1 mW.

The values for the calibration uncertainty are saved in the corresponding data memory; they are also listed on the German Accreditation Body (DAkkS) calibration certificate (item **1. Absolute Accuracy**) or in the specifications for the R&S[®] NRVC (data sheet/technical information, **Measurement uncertainty**). These values apply when the R&S[®] NRVC has been calibrated with DC voltage (see **4 Verification**).

21. Mismatch uncertainty at the test port of the power standard

Mismatching can cause the power fed to the DUT to be larger or smaller than the value that would occur in the case of ideal matching. Different measurement uncertainty contributions are obtained depending on the correction of this influence.

Without gamma correction

If the mismatch is not corrected because no complex reflection coefficients are available, for example, the following standard uncertainty is obtained assuming a u distribution:

$$\frac{u_{\text{m,NRVC}}}{\text{dB}} = 6.142 \cdot |\Gamma_{\text{eq}}| \cdot |\Gamma_{\text{load}}|$$

$|\Gamma_{\text{eq}}|$ is the magnitude of the equivalent reflection coefficient at the test port and $|\Gamma_{\text{load}}|$ is the magnitude of the reflection coefficient of the connected load, i.e. $|\Gamma_{\text{load}}| = |\Gamma_{\text{DUT}}|$ for the case in which the DUT is

connected directly to the test port and $|\Gamma_{\text{load}}| = |s_{11}|$ for a calibration via the reference attenuator. s_{11} is saved with its real and imaginary parts in the file **at(NRVC.002)<serial no.>** on the data diskette **CALIBRATION DATA***, and $|\Gamma_{\text{DUT}}|$ is to be provided by the user in the measurement file **rf(NRVC.002)<serial no.>**. If file **rf(NRVC.002)<serial no.>** is missing, either the reflection coefficients saved in the data memory of the DUT are retrieved or – if these are also not available – the data from the configuration file for the corresponding sensor type is applied. The individual measured values for $|\Gamma_{\text{eq}}|$ are saved in the data memory of the power standard; they are also provided on the German Accreditation Body (DAkkS) calibration certificate (section **3. Reflection Coefficient**) or in the file **rf(NRVC.002)<serial no.>** for the power standard.

With gamma correction

If complex matching measured values are present for the DUT, the measurement errors caused by mismatching can largely be corrected (gamma correction). The remaining uncertainty is then very small and can be calculated with the following equation:

$$\frac{u_{m(\Gamma),\text{NRVC}}}{\text{dB}} = 8.686 \cdot \sqrt{|\Gamma_{\text{eq}}|^2 u_{\Gamma_{\text{load}}}^2 + |\Gamma_{\text{load}}|^2 u_{\Gamma_{\text{eq}}}^2 + u_{\Gamma_{\text{load}}}^2 u_{\Gamma_{\text{eq}}}^2}$$

In the above equation, $u_{\Gamma_{\text{eq}}}$ and $u_{\Gamma_{\text{load}}}$ represent a standard uncertainty for the parameters $|\Gamma_{\text{eq}}|$ and $|\Gamma_{\text{load}}|$.

22. Linearity uncertainty of the power standard

For any power level at the test port that deviates from a power of 1 mW, the R&S®NRVD automatically corrects linearity errors while taking into consideration the individual transmission characteristic for the corresponding power standard. This characteristic is calculated during calibration of the power standard with DC voltage**) and saved in the data memory in the form of several second-order polynomials. The residual linearity uncertainty after correction is entered into the data memory of the power standard and included in the specifications for the R&S®NRVC (data sheet/technical information). It can also be obtained from the accredited calibration certificate under item **2. Linearity**.

23. Influence of the ambient temperature on the power standard

The influence of the ambient temperature on the measurement uncertainty of the power standard is calculated in the same manner by the R&S®NRVD as in item **8** (see also specifications for the R&S®NRVC, parameter = temperature coefficient of power display).

24. Zero offset and display noise of the power standard

Analogously to item **9.**, the following formulation is used for standard uncertainty:

$$\frac{u_{z+n,\text{NRVC}}}{\text{dB}} = 2.172 \cdot \frac{\sqrt{P_{z,\text{NRVC}}^2 + 2^{11-F} \cdot P_{n11,\text{NRVC}}^2}}{P_{\text{cal}}}$$

In the equation, $P_{z,\text{NRVC}}$ is the limit value for the absolute zero offset (approx. 2 standard deviations) specified for the power standard and saved in the data memory, $P_{n11,\text{NRVC}}$ is the 2σ value of the noise in W specified for filter setting 11, P_{cal} is the power at the test port and F is the number of the averaging filter set on the R&S®NRVD ($F = 5$ for R&S®NRV-Z51; $F = 8$ for R&S®NRV-Z54; $F = 7$ for all other sensors).

25. Quantization noise

*) CALIBRATION DATA FOR 20 DB REFERENCE ATTENUATOR for the units delivered in 1998.

**) Due to the polarity sensitivity of the thermal sensor in the power standard, all measurements are performed with positive and negative polarity and the arithmetic average is used for further processing.

In the event of underranging, the quantization noise of the A/D converter can influence the uncertainty. Since the calibration power and measurement range are appropriately selected by **R&S®Recal+**, this influence remains negligible in the sensor calibration.

26. Measurement uncertainty of R&S®NRVD base unit after DC calibration of power standard

If the power standard is used in the same measurement channel and measurement range during calibration of absolute accuracy as during the determination of correction factors K_{NRVC} and K_{ATT} (see **Verification**), the influence of the base unit (apart from noise and zero offset) is negligible. The measurement error of the base unit occurs in both cases with the same magnitude and the same sign. The situation is different if different measurement channels and measurement ranges are used. Based on measurement uncertainty $u_{NRVD,1}$ of the base unit for absolute power measurements (see **9**), the following standard uncertainty is used for the measurement uncertainty of a measurement range relative to another range:

$$\frac{u_{NRVD,2}}{\text{dB}} = \sqrt{2 \cdot u_{NRVD,1}^2}$$

Due to correlation between measurement ranges, this measurement uncertainty may in fact be less.

Additional Influence Quantities for the Measurement Uncertainty of the R&S®NRVC Power Standard with 20 dB Reference Attenuator ^②

27. Calibration uncertainty of 20 dB reference attenuator ^②

This factor is the uncertainty used to perform the calibration of S-parameter s_{21} . It is saved as an expanded uncertainty in dB together with S-parameters s_{11} , s_{21} and s_{22} in the **at(<NRVC.002><serial no.>** file on data disk **CALIBRATION DATA**. The values are also available on the German Accreditation Body (DAkkS) calibration certificate for the attenuator or the R&S®NRVC specification (data sheet/technical information).

28. Mismatch uncertainty between DUT and reference attenuator

Mismatching can cause the power fed to the DUT to be larger or smaller than the value that can be calculated merely by taking into account parameter $|s_{21}|$ for the reference attenuator. Different measurement uncertainty contributions are obtained depending on the correction of this influence.

Without gamma correction

If the mismatch is not corrected because no complex reflection coefficients are available, for example, the following standard uncertainty is obtained assuming a u distribution:

$$\frac{u_{m,att}}{\text{dB}} = 6.142 \cdot |s_{22}| \cdot |r_{DUT}|$$

In the equation, $|\Gamma_{\text{DUT}}|$ and $|s_{22}|$ are the magnitudes of the reflection coefficients of the DUT and the reference attenuator at the common interface. s_{22} is saved with its real and imaginary parts in the **at(NRVC.002)<serial no.>** file on data disk **CALIBRATION DATA****, and Γ_{DUT} is to be provided by the user in the measurement file **rf(NRVC.002)<serial no.>**. If file **rf(NRVC.002)<serial no.>** is missing, either the reflection coefficients saved in the data memory of the DUT are retrieved or – if these are also not available – the data from the configuration file for the corresponding sensor type is applied.

With gamma correction

If complex matching measured values are present for the DUT, the measurement errors caused by mismatching can largely be corrected (gamma correction). The remaining uncertainty is then very small and can be calculated with the following equation:

$$\frac{u_{m(r),\text{att}}}{\text{dB}} = 8.686 \cdot \sqrt{|s_{22}|^2 u_{\Gamma_{\text{DUT}}}^2 + |\Gamma_{\text{DUT}}|^2 u_{s_{22}}^2 + u_{\Gamma_{\text{DUT}}}^2 u_{s_{22}}^2}$$

In the above equation, $u_{s_{22}}$ and $u_{\Gamma_{\text{DUT}}}$ represent a standard uncertainty for the parameters $|s_{22}|$ and $|\Gamma_{\text{DUT}}|$. For $u_{s_{22}}$, a fixed value of 0.01 is used.

29. Reproducibility of RF connection at output of reference attenuator ②

Calculation is performed as described under **2**.

Linearity

The uncertainty of linearity measurements using the R&S®NRVC-B2 linearity standard is calculated by **R&S®Recal+** based on the ISO guide. The following influence quantities are considered:

Table 6-21 Influence quantities for uncertainty in linearity measurements

Item no	Influence quantity
1	Calibration uncertainty of linearity standard
2	Ambient temperature (DUT, linearity standard)
3	Zero offset and display noise (DUT, linearity standard)
4	Measurement uncertainty of R&S®NRVD base unit for relative power measurements (DUTs in R&S®NRV-Z and R&S®URV5-Z series, linearity standard)

The individual influence quantities are explained below:

1. Calibration uncertainty of the linearity standard

The transmission characteristic (DC output voltage versus RMS value of supplied AC voltage) is measured on an AC voltage calibrator at a frequency of 100 kHz and saved in the form of several second-order polynomials in the data memory of the linearity standard. The polynomials are used by the R&S®NRVD in every measurement to correct measured values. This is valid up to at least 50 MHz. The expanded measurement uncertainty (k=2) remaining after correction is shown in the following table. For a reference level of 0 dBm, this uncertainty can also be obtained from the German Accreditation Body (DAkkS) calibration certificate for the R&S®NRVC-B2.

Table 6-22 Expanded measurement uncertainty of the lin. standard for relative measurements (23 °C)

Meas. level ⇒	-30 dBm to < -10 dBm	-10 dBm to < 0 dBm	0 dBm to +33 dBm
⇓ Reference level Pref			
-30 dBm to < -10 dBm	0.020 dB	0.020 dB	0.020 dB
-10 dBm to < 0 dBm	0.020 dB	0.016 dB	0.016 dB
0 dBm to +33 dBm	0.020 dB	0.016 dB	0.013 dB

The reference level is identical to the level at which the calibration of absolute accuracy of the DUT is performed. It is simultaneously the smallest level of the linearity measurement for the corresponding type of sensor (Table 6-23 and Table 6-24).

Table 6-23 Reference levels for calibration of linearity, R&S®NRV and R&S®URV5 sensors

Sensor type ⇒	R&S®NRV-												R&S®URV5-			
	Z1	Z2	Z2	Z2	Z2	Z15	Z31	Z32	Z33	Z51	Z52	Z53	Z54	Z2	Z4	Z7
Pref / dBm	-30	-10	-30	-30	-30	-30	-20	±0	+10	±0	±0	+10	+10	+10	+20	+25

Table 6-24 Reference levels for calibration of linearity, R&S[®]NRP and R&S[®]FSH sensors

Sensor type ⇒	R&S [®] NRP-																R&S [®] FSH-		
	Z11	Z21	Z22	Z23	Z24	Z31	Z91	Z92	Z51	Z52	Z55	Z56	Z81	Z85	Z86	Z211	Z221	Z1	Z18
Pref / dBm	±0	±0	+10	+20	+25	±0	±0	±10	±0	±0	±0	±0	-10	-10	-10	-10	-10	±0	±0

Note: Since the linearity measurements for the R&S[®]NRV-Z32/-Z33/-Z53/-Z54 and R&S[®]NRP-Z22/-Z23/-Z24 sensors are performed without the attenuator connected, the levels used for linearizing these sensors are less than the levels specified in Table 7-14 by the attenuation value.

The measurement uncertainties for the linearity standard stated in the specifications (data sheet/technical information) for the R&S[®]NRVC are slightly larger than those specified in Table 6-22 since the effects of the base unit and the ambient temperature have been taken into consideration.

2. Ambient temperature

For ambient temperatures not equal to 23 °C, their influence on the measured voltage or power ratio has to be taken into consideration for the linearity standard and the DUT. Analogously to item 8., a standard uncertainty $u_{T,\text{lin}}$ with the following value is applied:

$$\frac{u_{T,\text{lin}}}{\text{dB}} = (T - 296.15\text{K}) \cdot \sqrt{2(\alpha_{T,\text{DUT}}^2 + \alpha_{T,\text{B2}}^2)}$$

In the equation, $\alpha_{T,\text{DUT}}$ is a standard deviation for the residual temperature coefficient of the DUT for absolute power measurements and $\alpha_{T,\text{B2}}$ is a standard deviation for the residual temperature coefficient of the linearity standard for relative measurements (data sheet/technical information on the R&S[®]NRVC). The factor 2 indicates that the temperature coefficients for the measurement level and the reference level can be different.

3. Zero offset and display noise

The influence of zero offset and display noise on the accuracy of the linearity standard and the DUT is very small compared with the other influence quantities. The equations provided in item 5. are used in the calculation, and specifically for the smaller of the two levels.

4. Measurement uncertainty of the base unit for relative power measurements

The R&S[®]NRVD base unit has a linear response within the measurement range. When there are different measurement ranges for the two measurement points of a voltage/power ratio, however, differences in the two ranges can cause linearity errors. The following equation is applied for the standard uncertainty $u_{\text{NRVD},\text{lin}}$

$$\frac{u_{\text{NRVD},\text{lin}}}{\text{dB}} = \sqrt{R} \cdot u_{\text{NRVD},1}$$

($u_{\text{NRVD},1}$, see item 9). Factor R arises from the fact that several voltage/power measurements are performed at one test point for the linearity calibration. For the R&S[®]NRV and R&S[®]URV5 sensors, R , strictly speaking, would be equal to 4 because two measurements each are performed with the DUT and the linearity standard. Due to the calibration of the two R&S[®]NRVD measurement channels with the same DC voltage calibrator and since shared circuit components are used in both channels of the R&S[®]NRVD, a certain correlation exists between individual measurement ranges and channels and $R = 3$ is assumed. For the R&S[®]NRP sensors, $R = 2$ because only the linearity standard is connected to the R&S[®]NRVD.